

50Hz



GENERAL CATALOGUE

www.pentax-pumps.it



HISTORY

For many years **Pentax** has held a large share of the world market for motorized pumps. The sales department is constantly working to better serve existing customers and to open up new markets. This is possible thanks to the wide range of products available which allows to cover most of the applications in the pump field. Special attention is also paid to market surveys, so that any new requirements can be immediately transferred to the research and development department: the best way to properly develop and forecast future scenarios.

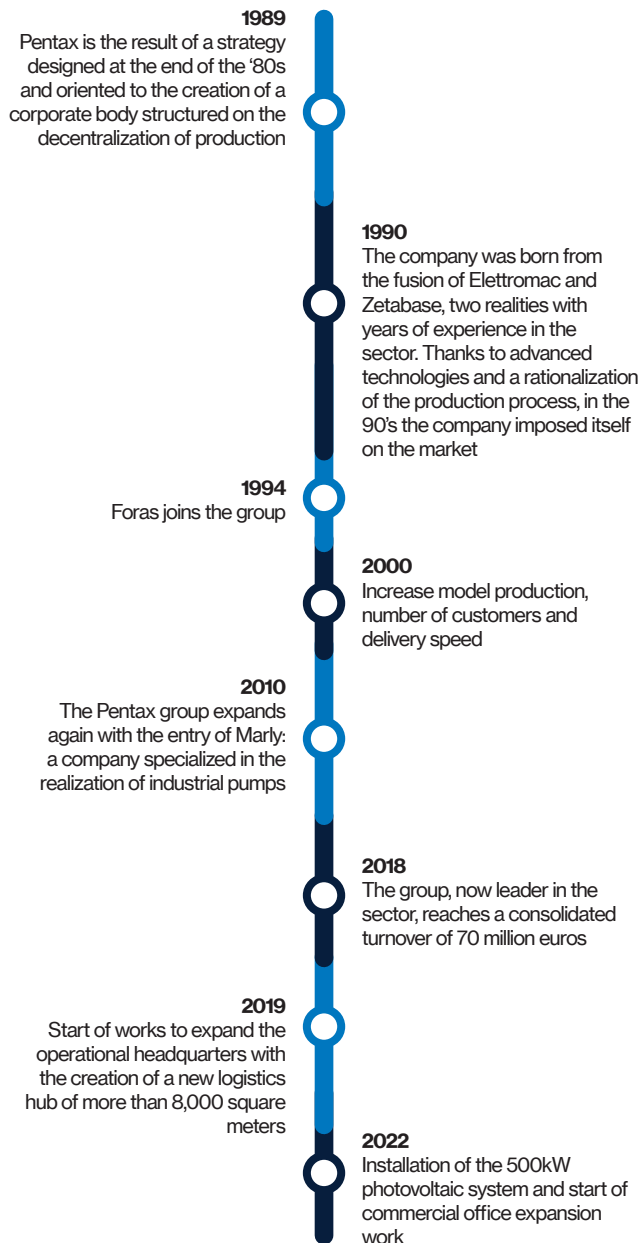

MISSION

After more than **20 years of activity** we can finally trace the guidelines that have governed and directed the industrial development of **Pentax Industries SpA**. Actions and processes that have intersected with the obvious aim of creating value, benefits to be redistributed to the various components of the production and distribution process.

A rational allocation of available resources, together with a refined program of production decentralization have allowed the company to adapt to changing market conditions, each time with extreme rapidity.

Maximum attention to the markets, therefore, with the commitment to respond in real time to the specific needs of the different markets, paying particular attention to technological progress. All this in the perspective of a careful policy for **customer satisfaction**.

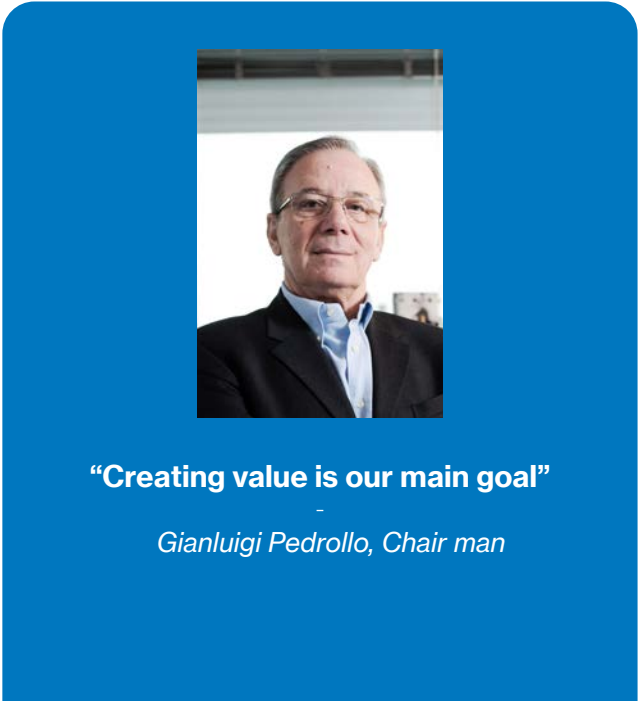

VALUES



Reliability

Choosing Pentax means choosing safety at every stage

Quality

Where there is control, there is reliability: the basis for success

Speed

Impeccable delivery time

Flexibility

Pentax studies each case thoroughly, identifies the best solution and then takes action with security

Variety

The best service: a wide range of Pentax products, one for every need



OFFICIAL JOURNAL OF THE EUROPEAN UNION

Regulation UE 547/2012

ANNEX II

«The benchmark for most efficient water pumps is $MEI \geq 0,70$ ».

«The efficiency of a pump with a trimmed impeller is usually lower than that of a pump with the full impeller diameter. The trimming of the impeller will adapt the pump to a fixed duty point, leading to reduced energy consumption. The minimum efficiency index (MEI) is based on the full impeller diameter».

«The operation of this water pump with variable duty points may be more efficient and economic when controlled, for example, by the use of a variable speed drive that matches the pump duty to the system».

Information on benchmark efficiency is available at:

www.europump.org/efficiencycharts.





Pumps ideal for counter-current swimming, water parks, fountains, waterfalls, etc. The pump body in polypropylene reinforced with glass fiber allows to resist the chemicals of the pools and guarantee excellent durability.

Construction features

Painting	cataphoresis
Pump body, seal housing, diffuser	polypropylene + fiberglass
Motor bracket	aluminum
Impeller	Noryl®, marine bronze on request
Mechanical seal	ceramic-graphite-AISI 316
Motor shaft	stainless steel AISI 316
Liquid temperature	max 40 °C

Motor

2 poles induction motor	1~ 230V - 50Hz 3~ 230/400V - 50Hz
Insulation class	F
Protection degree	IP55



POOL5

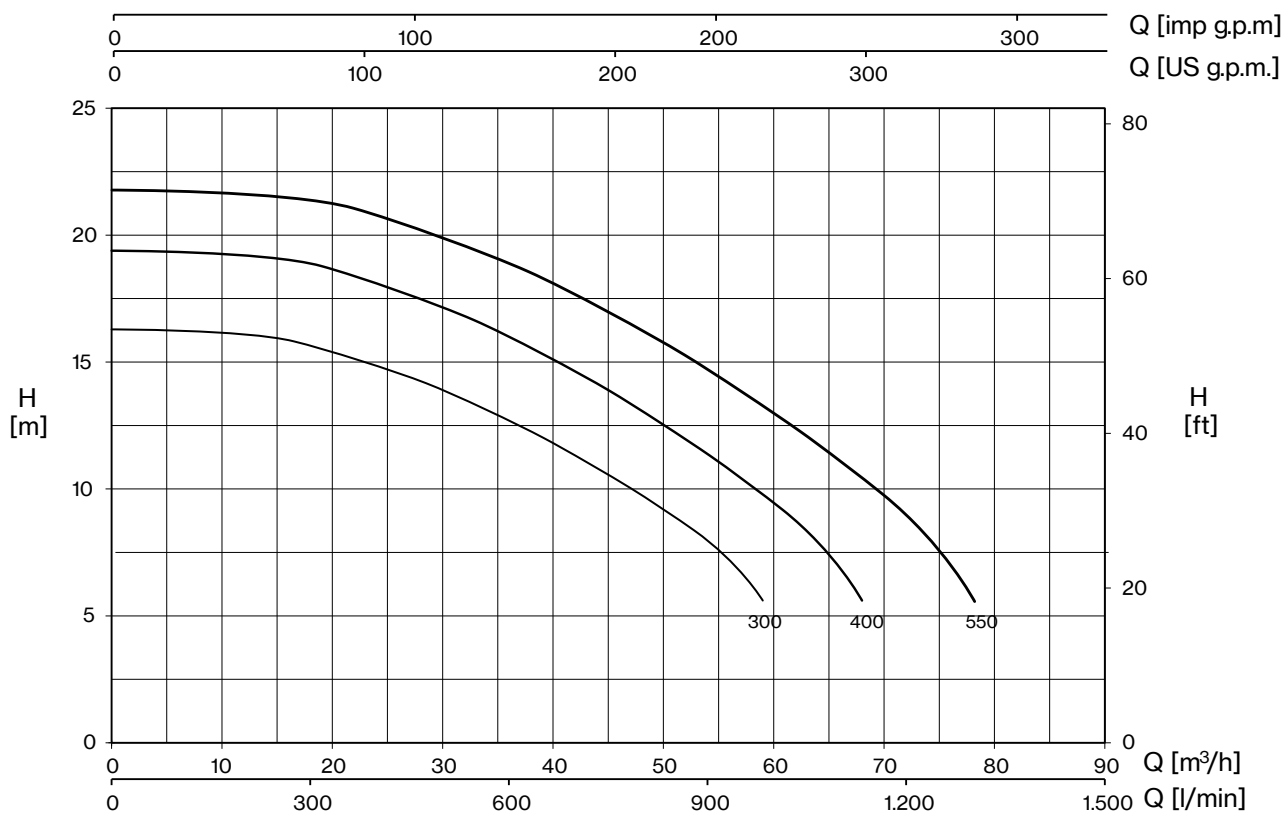

TYPE		P2		AMPERE			H (m)						
1~	3~	HP	kW	1~	3~	3~	6	8	10	12	14	16	18
				230V	230V	400V	Q (m³/h)						
POOL5 300M	POOL5 300T	3	2,2	16	9,4	5,3	59,0	54,0	47,0	39,0	28,0	16,0	
	POOL5 400T	4	3	-	12,5	6,9	68,0	63,0	58,0	52,0	45,0	36,0	23,0
	POOL5 550T	5,5	4	-	-	8,8	78,0	74,0	70,0	65,0	59,0	50,0	39,0

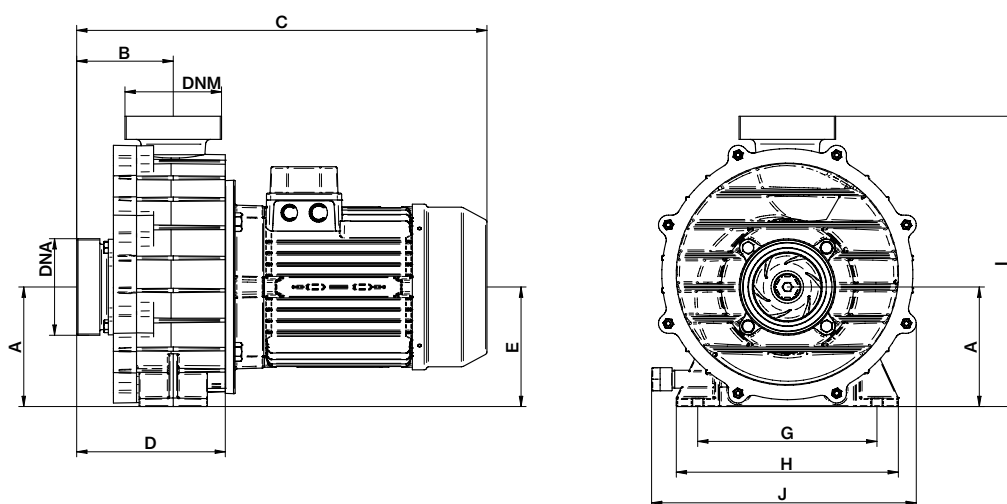

TYPE	DIMENSIONS (mm)										Kg
	A	B	C	D	E	G	H	I	J	DNA	
POOL5 300M	140	113	480	174	140	210	260	420	310	3" Ø 90 PVC	23
POOL5 300T	140	113	480	174	140	210	260	420	310		28
POOL5 400T	140	113	480	174	140	210	260	420	310		37
POOL5 550T	140	113	480	174	140	210	260	420	310		

