

**50Hz**



# **GENERAL CATALOGUE**

**Edition 2022**

[www.pentax-pumps.it](http://www.pentax-pumps.it)

# Where there's water there's Pentax



Viale dell'Industria, 1  
37040 Veronella (VR) - Italia  
Tel. +39 0442 489500  
Fax +39 0442 489510  
com@pentax-pumps.it  
[www.pentax-pumps.it](http://www.pentax-pumps.it)

**PENTAX s.p.a.**



# 8LR & 8LM lines

Deepwell Borehole



8LR line

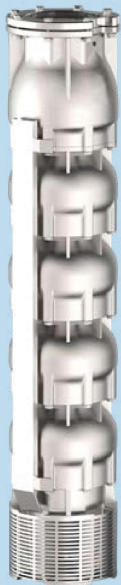

8LM line



Submersible multistage centrifugal pumps for 8" wells. Check valve built into the delivery outlet. Pump flange for coupling with motors are made according to NEMA standards. Most common applications are civil and agricultural. All components are made of stainless steel with lost wax Microfusion technology. The standard material is AISI 304 stainless steel, alternatively the following materials are available on request: AISI 316 Steel, Duplex steel, AISI 904L Steel. Bushing bearings and wear-rings made of sand abrasion-resistant rubber, reverse-Thrust ring in PTFE/ Graphite.

### General operating data:

- Capacity up to 860 m<sup>3</sup>/h
- Pressure up to 800 m
- Hydraulic efficiency 8", up to 81,5%
- Pressure up to 80 bar
- Powers up to 400 kW
- Rotation speed up to 3600 rpm
- Maximum depth: 350 m
- Maximum quantity of permitted sand: 100 gr/m<sup>3</sup>
- Drinking water compatibility according to DM174 MEI  $\geq 0,4$  (EU directive No.547/2012)
- Performance tolerance: ISO9906-3B.

### Construction features

<b>Suction and delivery outlet</b>	stainless steel AISI 304 (LRS-LMS) stainless steel AISI 316 (LRX-LMX) Duplex (LRD-LMD)
<b>Valve</b>	stainless steel AISI 304 (LRS-LMS) stainless steel AISI 316 (LRX-LMX) Duplex (LRD-LMD)
<b>Impellers and diffusers</b>	stainless steel AISI 304 (LRS-LMS) stainless steel AISI 316 (LRX-LMX) Duplex (LRD-LMD)
<b>Upper bushings</b>	NBR rubber
<b>Shaft pump side</b>	stainless steel AISI 304 (LRS-LMS) stainless steel AISI 316 (LRX-LMX) Duplex (LRD-LMD)
<b>Quantity of sand in the water</b>	max 100 gr/m <sup>3</sup>

### Motor

<b>Asynchronous 2 pole</b>	rewindable water cooled
<b>Insulation class</b>	Y (max 30 °C) - PPC winding type F (max 50 °C) - PE2+PA or LPE winding type
<b>Protection degree</b>	IP68
<b>Liquid temperature</b>	max 30 °C (max 50 °C on request)
<b>Depth of immersion</b>	max 350 m



# 8LM

## 8LM 80

Motor 50 Hz - 2900 rpm				Q									
TYPE	Power		400 V	l/min l/sec m <sup>3</sup> /h	0	300	400	600	800	1000	1200	1400	16
	HP	kW			A	0	5,0	6,7	10,0	13,3	16,7	20,0	23,3
					0	18	24	36	48	60	72	84	96
8LM 80/01	10	7,5	16,3	H[m]	27	26	26	24	23	22	20	18	15
8LM 80/02	17,5	13	27,3		54	53	51	49	47	44	40	35	30
8LM 80/03	25	18,5	38,3		81	79	77	73	70	65	60	53	44
8LM 80/04	35	26	52,9		108	105	103	97	93	87	80	70	59
8LM 80/05	40	30	61,1		135	132	129	122	117	109	100	88	74
8LM 80/06	50	37	75,8		162	158	154	146	140	131	120	105	89
8LM 80/07	60	45	86,3		189	184	180	170	163	153	140	123	104
8LM 80/08	75	55	106,2		216	210	206	194	186	174	160	140	118
8LM 80/09	75	55	106,2		243	237	231	219	210	196	180	158	133
8LM 80/10	90	66	126,0		270	263	257	243	233	218	200	175	148

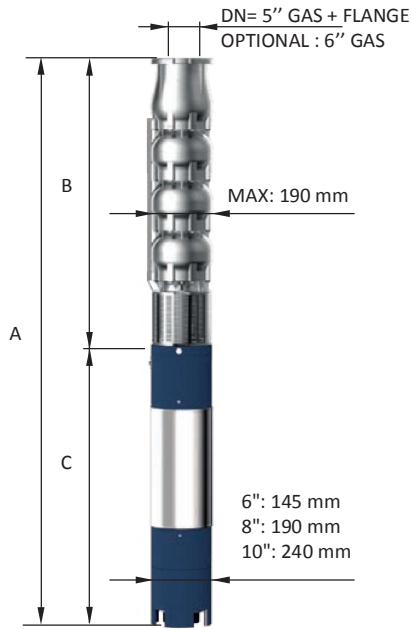

Motor 50 Hz 2900 rpm	DIMENSIONS (mm)			Weight (kg)	
TYPE	A	B	C	M	P
8LM 80/01	1164	463	701	55	19
8LM 80/02	1429	588	841	70	25
8LM 80/03	1704	713	991	83	32
8LM 80/04	2019	838	1181	100	38
8LM 80/05	2214	963	1251	108	45
8LM 80/06	2429	1088	1341	118	51
8LM 80/07	2336	1213	1123	178	58
8LM 80/08	2633	1400	1233	200	65
8LM 80/09	2758	1525	1233	200	71
8LM 80/10	2952	1650	1302	214	78

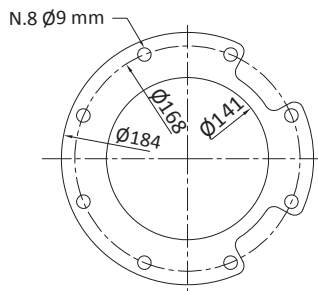

FOR COMMERCIAL TUBE  
EXTERNAL DIAMETER: 139,7 mm

Max Eff. % =	74
Max kW / St. =	5,75

Q (flow)	25%	50%	75%	100%
NPSH (m)	3	3	3,5	4,5



8LM 80

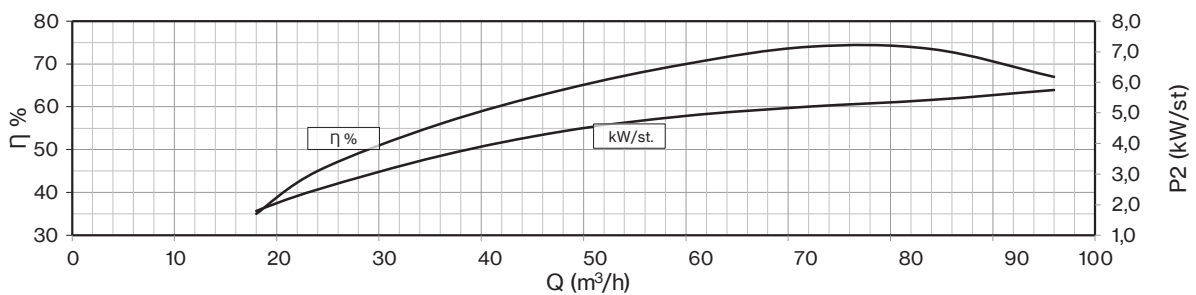
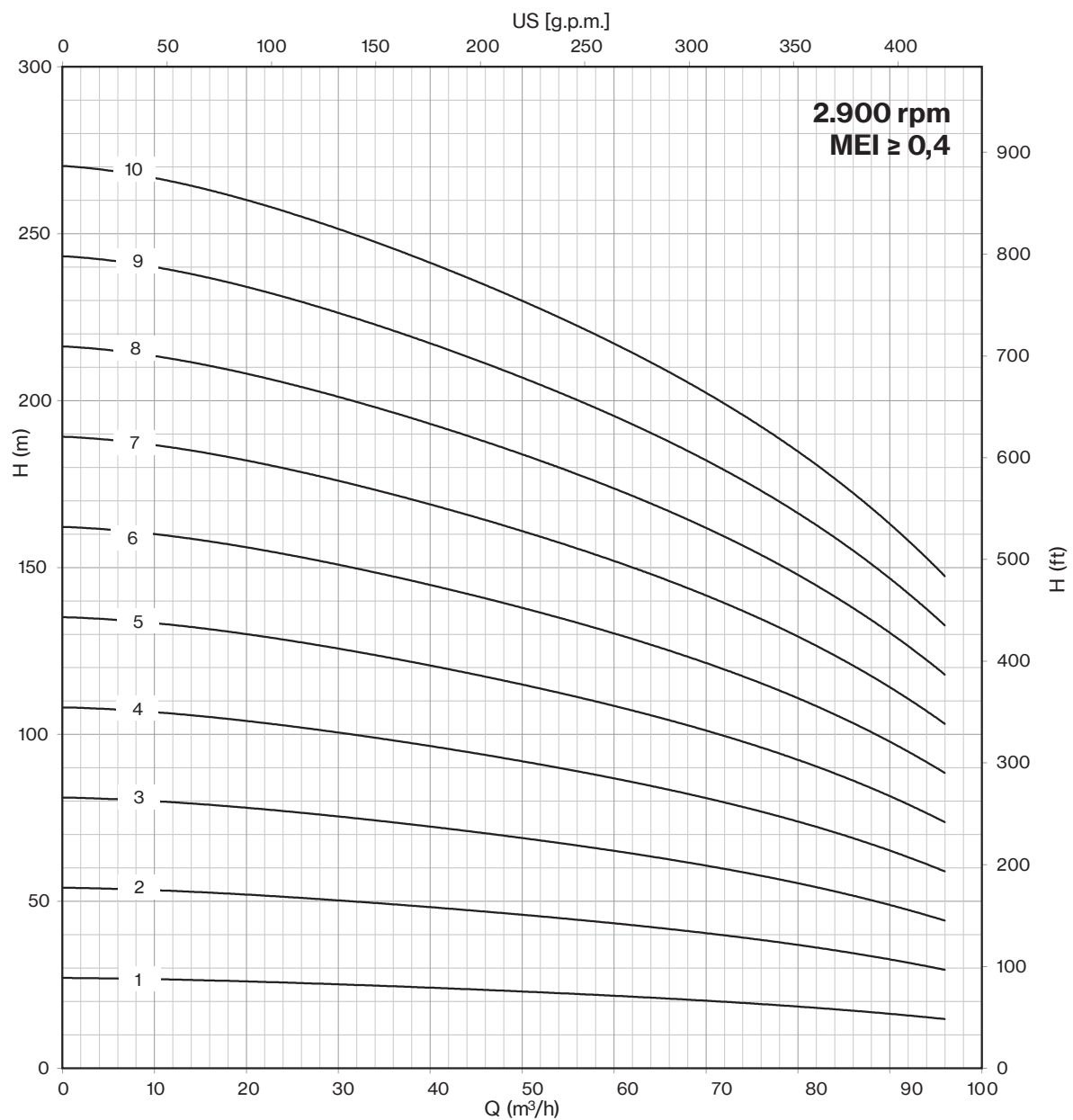

# 8LM

## 8LM 80

Motor 50 Hz - 2900 rpm				Q									
TYPE	Power		400 V	l/min l/sec m <sup>3</sup> /h	0	300	400	600	800	1000	1200	1400	16
	HP	kW			A	0	5,0	6,7	10,0	13,3	16,7	20,0	23,3
				H[m]	0	18	24	36	48	60	72	84	96
8LM 80/11	90	66	126,0	H[m]	297	289	283	267	256	240	220	193	163
8LM 80/12	100	75	143,2		324	316	308	292	280	262	240	210	178
8LM 80/13	100	75	143,2		351	342	334	316	303	283	260	228	192
8LM 80/14	125	92	175,1		378	368	360	340	326	305	280	245	207
8LM 80/15	125	92	175,1		405	395	386	365	350	327	300	263	222
8LM 80/16	125	92	175,1		432	421	411	389	373	349	320	280	237
8LM 80/17 D	150	110	211,0		459	447	437	413	396	371	340	298	252
8LM 80/18 D	150	110	211,0		486	473	463	437	419	392	360	315	266
8LM 80/19 D	150	110	211,0		513	500	488	462	443	414	380	333	281
8LM 80/20 D	175	130	245,3		540	526	514	486	466	436	400	350	296

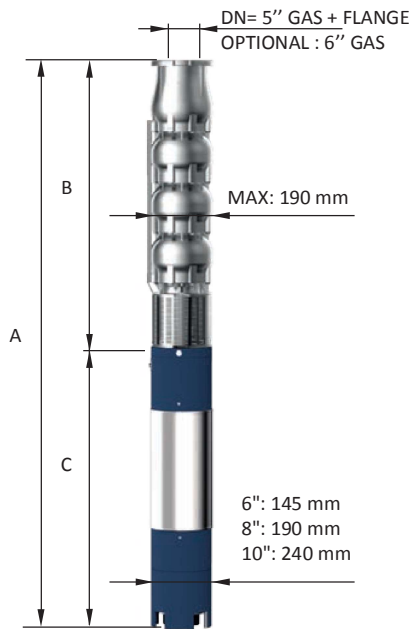

Motor 50 Hz 2900 rpm	DIMENSIONS (mm)			Weight (kg)	
TYPE	A	B	C	M	P
8LM 80/11	3077	1775	1302	214	84
8LM 80/12	3283	1900	1383	230	90
8LM 80/13	3408	2025	1383	230	97
8LM 80/14	3733	2150	1583	270	103
8LM 80/15	3858	2275	1583	270	110
8LM 80/16	3983	2400	1583	270	116
8LM 80/17 D	4258	2525	1733	300	123
8LM 80/18 D	4383	2650	1733	300	129
8LM 80/19 D	4508	2775	1733	300	136
8LM 80/20 D	4534	2900	1634	385	142

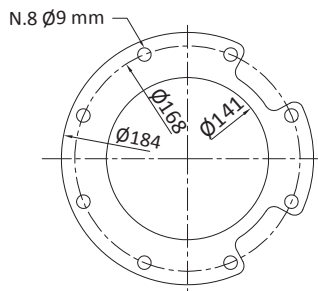

FOR COMMERCIAL TUBE  
EXTERNAL DIAMETER: 139,7 mm

Max Eff. % =	74
Max kW / St. =	5,75

Q (flow)	25%	50%	75%	100%
NPSH (m)	3	3	3,5	4,5

"D" Pump shaft in Duplex



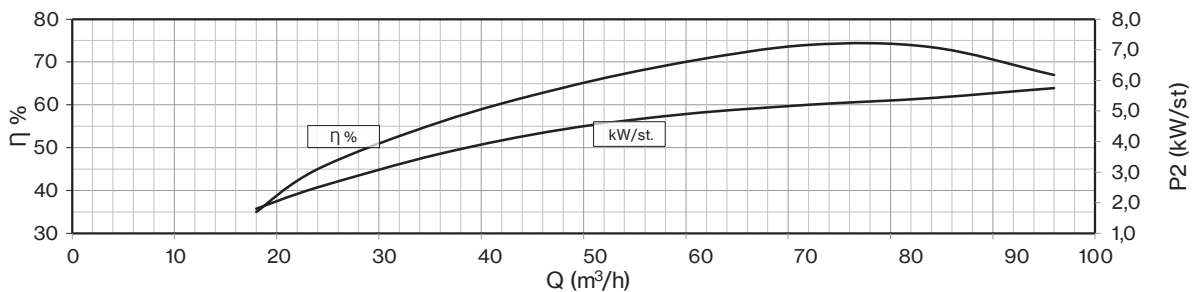
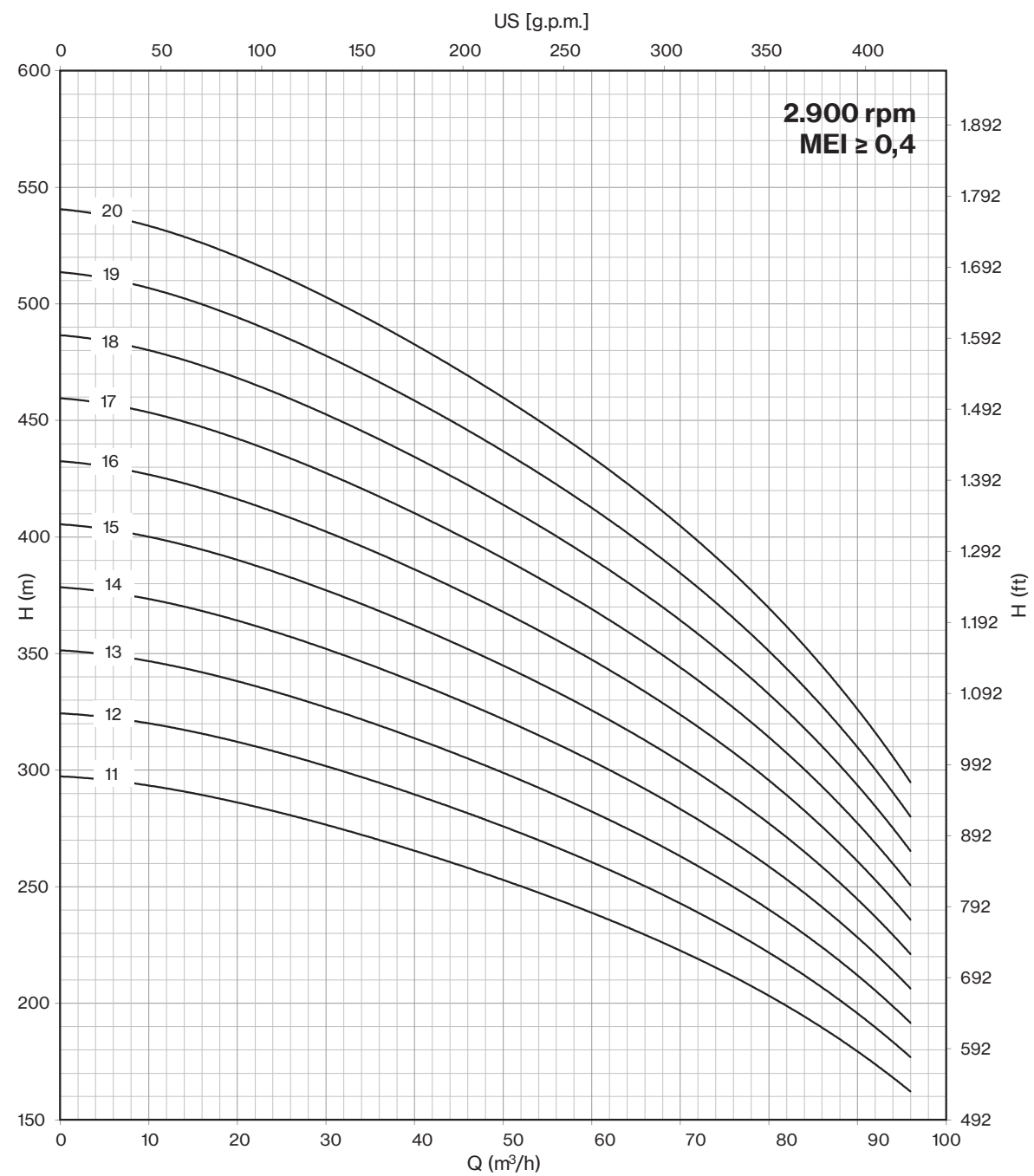

# 8LM

## 8LM 92

Motor 50 Hz - 2900 rpm				Q									
TYPE	Power		400 V	l/min	0	300	800	1000	1200	1400	1600	1800	2000
	HP	kW			A	l/sec	5,0	13,3	16,7	20,0	23,3	26,7	30,0
						m <sup>3</sup> /h	0	18	48	60	72	84	96
8LM 92/01	10	7,5	16,3	H[m]	27	26	24	23	22	20	18	16	13
8LM 92/02	17,5	13	27,3		54	53	49	47	44	40	36	31	25
8LM 92/03	30	22	45,1		81	79	73	70	65	60	54	47	38
8LM 92/04	35	26	52,9		108	105	97	93	87	80	72	62	50
8LM 92/05	50	37	75,8		135	132	122	117	109	101	90	78	63
8LM 92/06	60	45	86,3		162	158	146	140	131	121	107	93	76
8LM 92/07	75	55	106,2		189	184	170	163	153	141	125	109	88
8LM 92/08	75	55	106,2		216	210	194	186	174	161	143	124	101
8LM 92/09	90	66	126,0		243	237	219	210	196	181	161	140	113
8LM 92/10	90	66	126,0		270	263	243	233	218	201	179	155	126

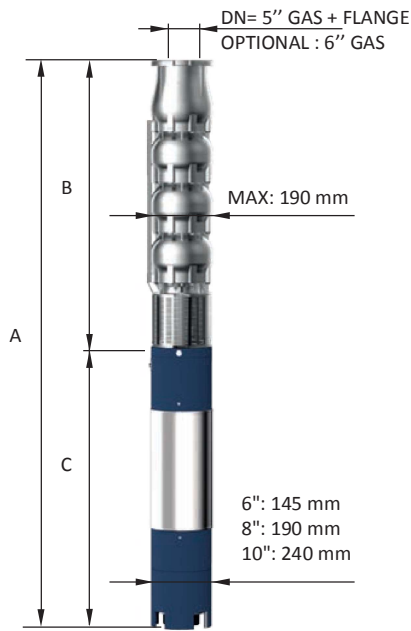

Motor 50 Hz 2900 rpm	DIMENSIONS (mm)			Weight (kg)	
TYPE	A	B	C	M	P
8LM 92/01	1164	463	701	55	19
8LM 92/02	1429	588	841	70	26
8LM 92/03	1784	713	1071	92	32
8LM 92/04	2019	838	1181	100	39
8LM 92/05	2304	963	1341	118	46
8LM 92/06	2211	1088	1123	178	53
8LM 92/07	2508	1275	1233	200	60
8LM 92/08	2633	1400	1233	200	67
8LM 92/09	2827	1525	1302	214	74
8LM 92/10	2952	1650	1302	214	81

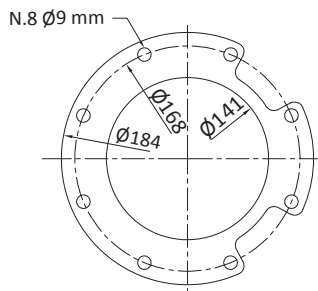

FOR COMMERCIAL TUBE  
EXTERNAL DIAMETER: 139,7 mm

Max Eff. % =	75
Max kW / St. =	6,47

Q (flow)	25%	50%	75%	100%
NPSH (m)	2,5	2,9	3,9	7,8





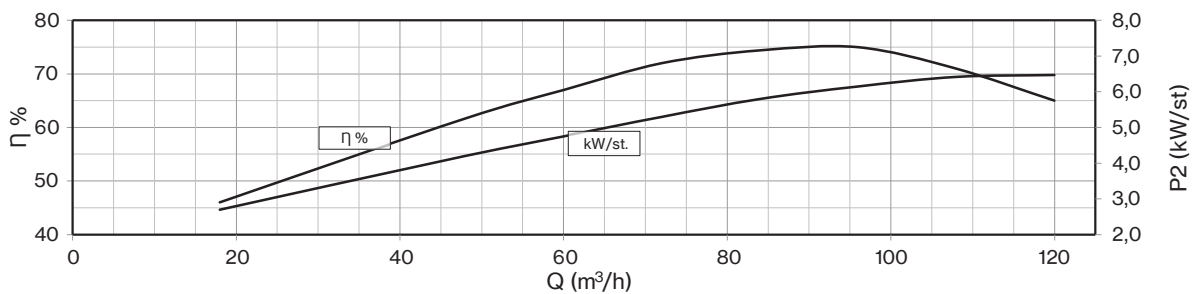
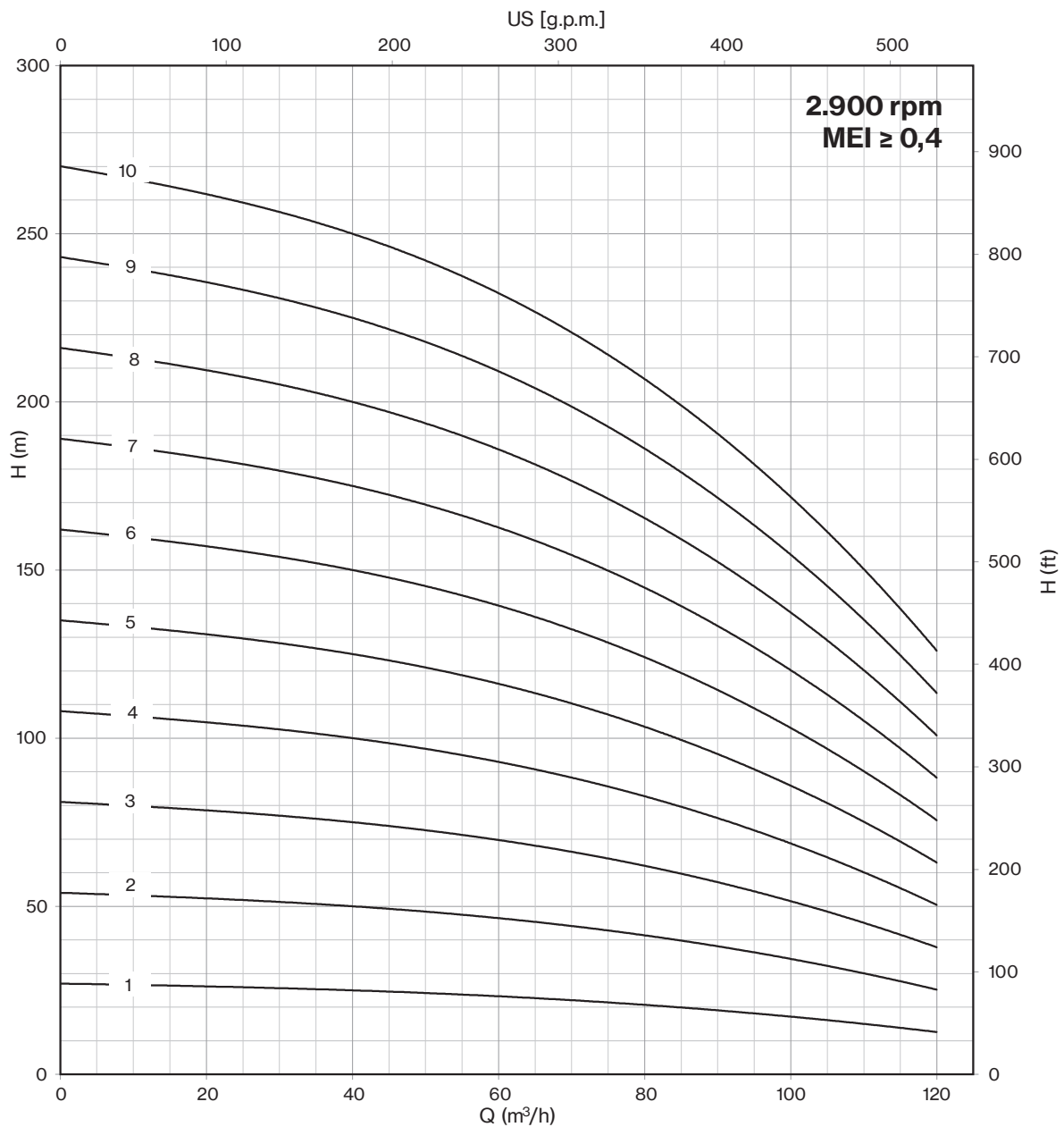

## 8LM 92

Motor 50 Hz - 2900 rpm				Q									
TYPE	Power		400 V	l/min	0	300	800	1000	1200	1400	1600	1800	2000
	HP	kW			A	l/sec	5,0	13,3	16,7	20,0	23,3	26,7	30,0
						m <sup>3</sup> /h	0	18	48	60	72	84	96
8LM 92/11	100	75	143,2	H[m]	297	289	267	256	240	221	197	171	139
8LM 92/12	125	92	175,1		324	316	292	280	262	241	215	186	151
8LM 92/13	125	92	175,1		351	342	316	303	283	261	233	202	164
8LM 92/14	125	92	175,1		378	368	340	326	305	281	251	217	176
8LM 92/15 D	150	110	211,0		405	395	365	350	327	302	269	233	189
8LM 92/16 D	150	110	211,0		432	421	389	373	349	322	286	248	202
8LM 92/17 D	150	110	211,0		459	447	413	396	371	342	304	264	214
8LM 92/18 D	175	130	245,3		486	473	437	419	392	362	322	279	227
8LM 92/19 D	175	130	245,3		513	500	462	443	414	382	340	295	239
8LM 92/20 D	175	130	245,3		540	526	486	466	436	402	358	310	252

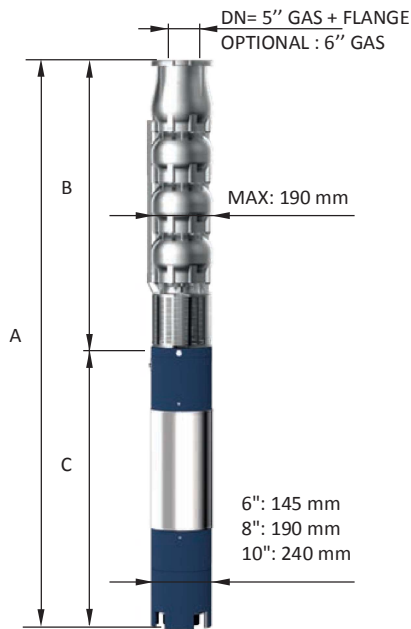

Motor 50 Hz 2900 rpm	DIMENSIONS (mm)			Weight (kg)	
	TYPE	A	B	C	M
8LM 92/11	3158	1775	1383	230	88
8LM 92/12	3483	1900	1583	270	94
8LM 92/13	3608	2025	1583	270	101
8LM 92/14	3733	2150	1583	270	108
8LM 92/15 D	4008	2275	1733	300	115
8LM 92/16 D	4133	2400	1733	300	122
8LM 92/17 D	4258	2525	1733	300	128
8LM 92/18 D	4284	2650	1634	385	138
8LM 92/19 D	4409	2775	1634	385	145
8LM 92/20 D	4534	2900	1634	385	152

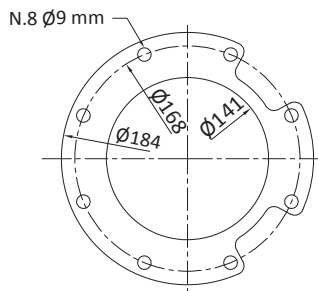

FOR COMMERCIAL TUBE  
EXTERNAL DIAMETER: 139,7 mm

Max Eff. % =	75
Max kW / St. =	6,5

Q (flow)	25%	50%	75%	100%
NPSH (m)	2,5	2,9	3,9	7,8

"D" Pump shaft in Duplex



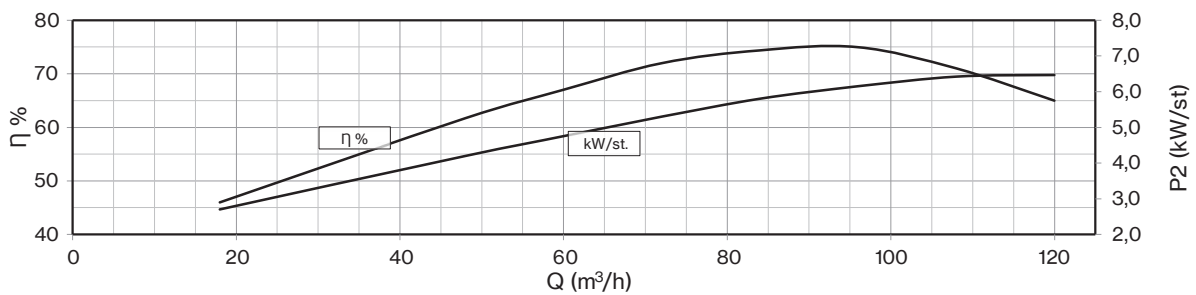
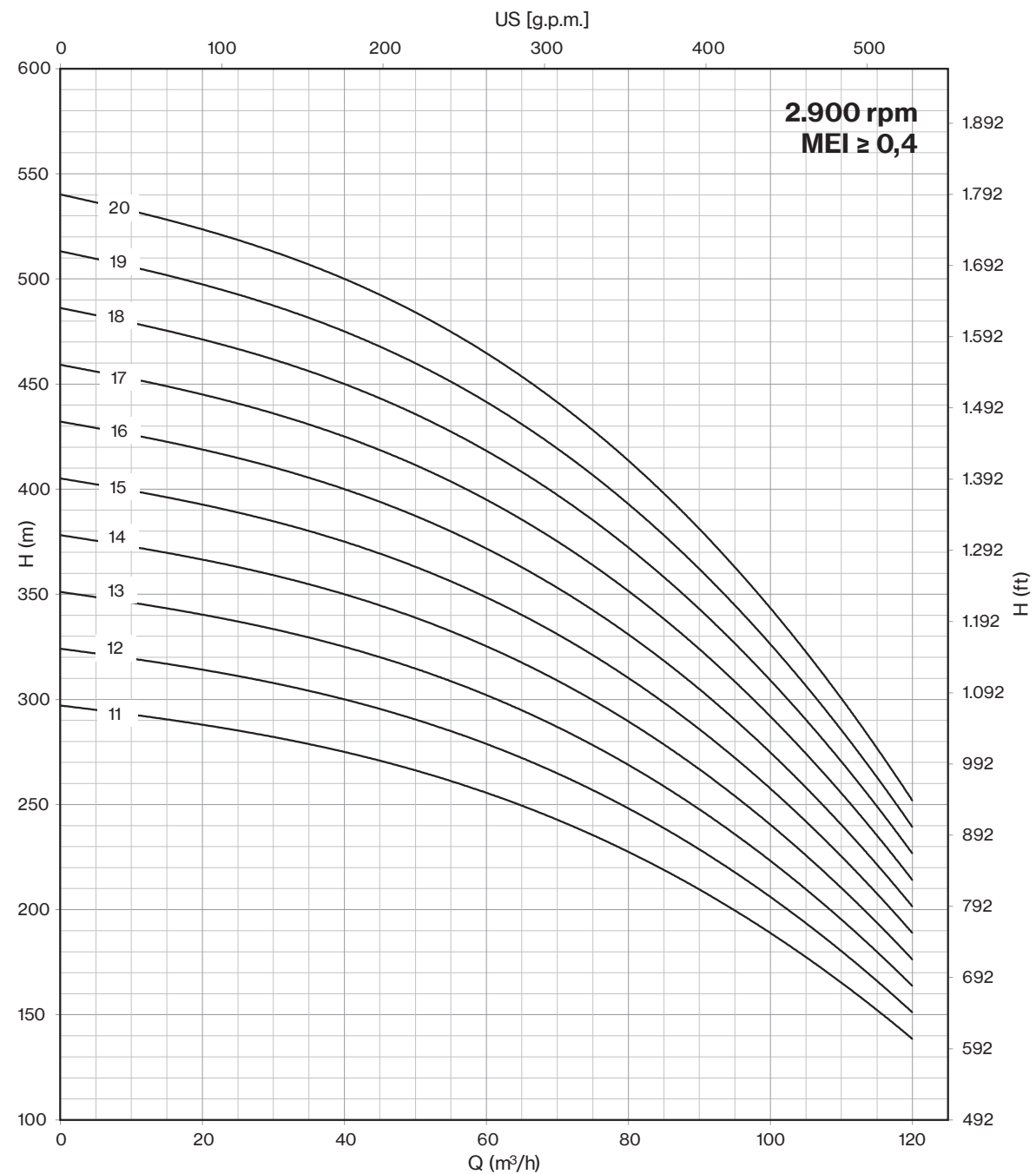

# 8LM

## 8LM 110

Motor 50 Hz - 2900 rpm				Q									
TYPE	Power		400 V	l/min l/sec m <sup>3</sup> /h	0	600	1200	1400	1600	1800	2000	2200	2400
	HP	kW			A	0	10,0	20,0	23,3	26,7	30,0	33,3	36,7
				H[m]	0	36	72	84	96	108	120	132	144
8LM 110/01	10	7,5	16,3	H[m]	28	25	22	21	20	19	17	15	13
8LM 110/02	20	15	31,5		55	51	44	42	41	38	35	31	26
8LM 110/03	30	22	45,1		83	76	65	63	61	57	52	46	38
8LM 110/04	40	30	61,1		110	101	87	84	82	76	69	62	51
8LM 110/05	50	37	75,8		138	127	109	106	102	96	87	77	64
8LM 110/06	60	45	86,3		165	152	131	127	122	115	104	92	77
8LM 110/07	75	55	106,2		193	177	153	148	143	134	121	108	90

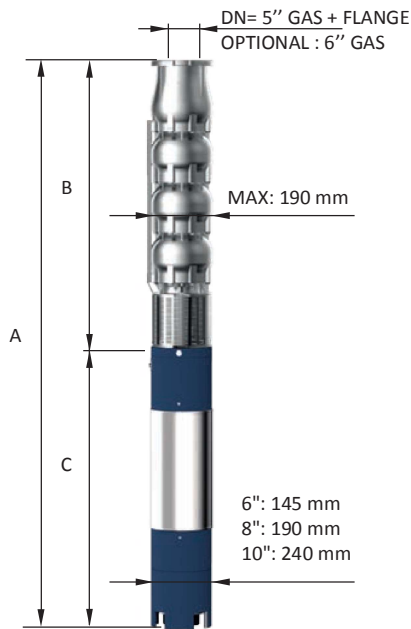

Motor 50 Hz 2900 rpm	DIMENSIONS (mm)			Weight (kg)	
TYPE	A	B	C	M	P
8LM 110/01	1164	463	701	55	19
8LM 110/02	1519	588	931	75	26
8LM 110/03	1784	713	1071	92	32
8LM 110/04	2089	838	1251	108	39
8LM 110/05	2304	963	1341	118	46
8LM 110/06	2273	1150	1123	178	54
8LM 110/07	2508	1275	1233	200	60

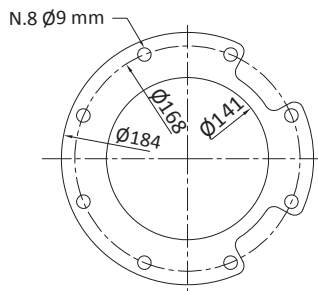

FOR COMMERCIAL TUBE  
EXTERNAL DIAMETER: 139,7 mm

Max Eff. % =	77
Max kW / St. =	7,2

Q (flow)	25%	50%	75%	100%
NPSH (m)	2,5	2,9	3,9	7,8



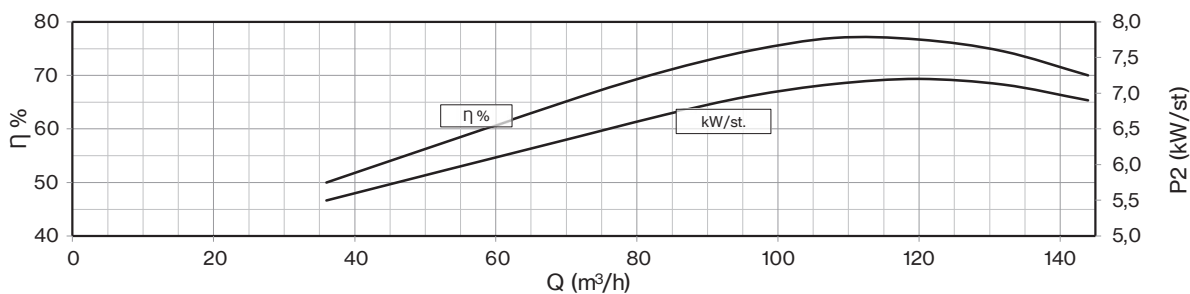
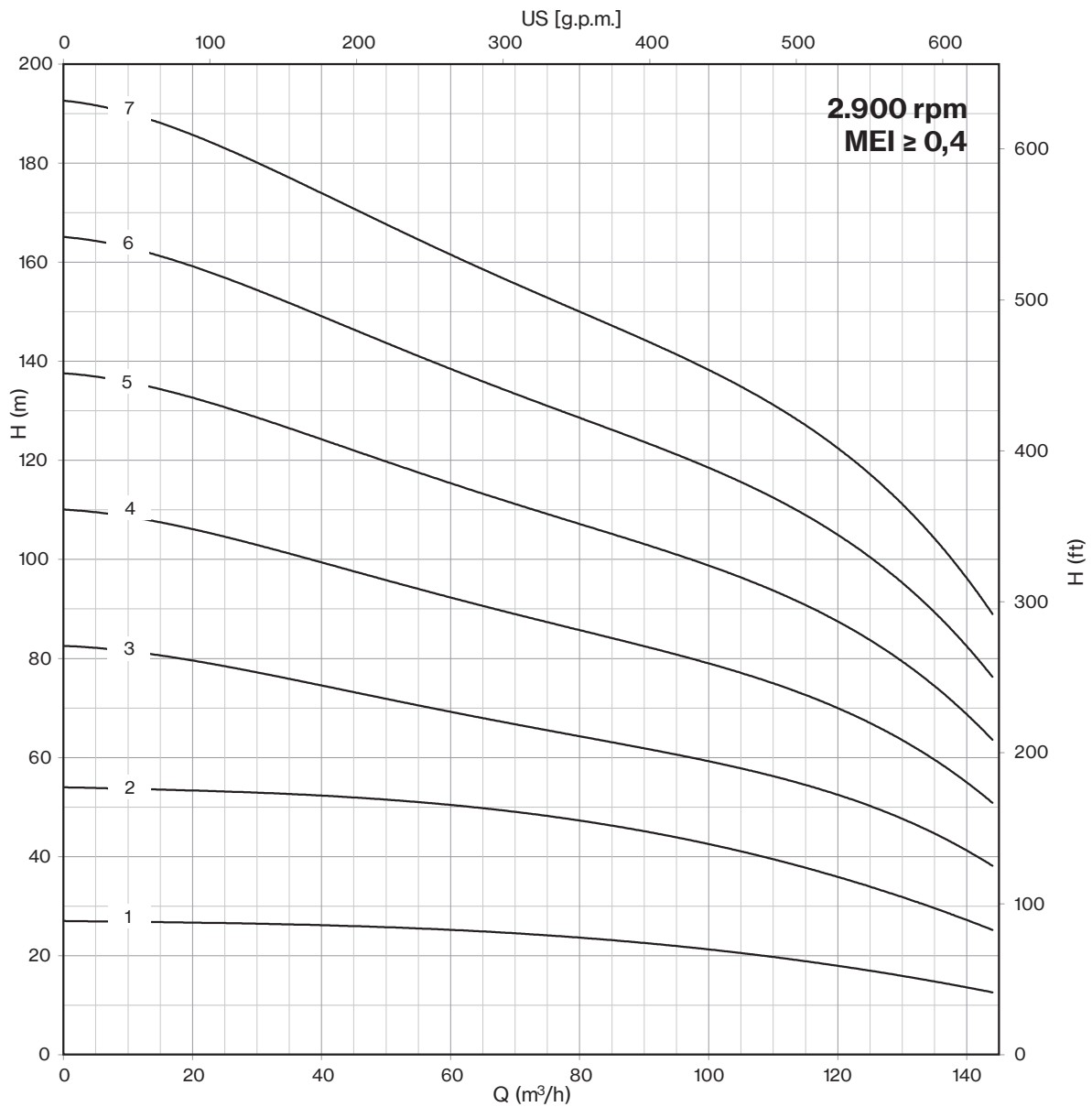

# 8LM

## 8LM 110

Motor 50 Hz - 2900 rpm				Q									
TYPE	Power		400 V	l/min l/sec m <sup>3</sup> /h	0	600	1200	1400	1600	1800	2000	2200	2400
	HP	kW			A	0	10,0	20,0	23,3	26,7	30,0	33,3	36,7
				H[m]	0	36	72	84	96	108	120	132	14
8LM 110/08	90	66	126,0	H[m]	220	202	174	169	163	153	138	123	102
8LM 110/09	90	66	126,0		248	228	196	190	184	172	156	139	115
8LM 110/10	100	75	143,2		275	253	218	211	204	191	173	154	128
8LM 110/11	125	92	175,1		303	278	240	232	224	210	190	169	141
8LM 110/12	125	92	175,1		330	304	262	253	245	229	208	185	154
8LM 110/13 D	150	110	211,0		358	329	283	274	265	248	225	200	166
8LM 110/14 D	150	110	211,0		385	354	305	295	286	267	242	216	179
8LM 110/15 D	150	110	211,0		413	380	327	317	306	287	260	231	192
8LM 110/16 D	175	130	245,3		440	405	349	338	326	306	277	246	205
8LM 110/17 D	175	130	245,3		468	430	371	359	347	325	294	262	218
8LM 110/18 D	175	130	245,3	495	455	392	380	367	344	311	277	230	

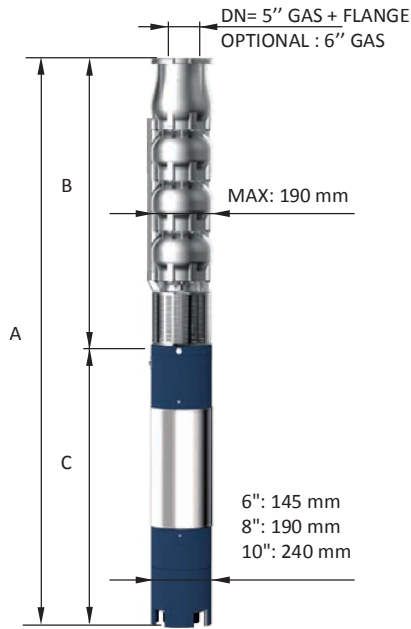

Motor 50 Hz 2900 rpm	DIMENSIONS (mm)			Weight (kg)	
TYPE	A	B	C	M	P
8LM 110/08	2702	1400	1302	214	67
8LM 110/09	2827	1525	1302	214	74
8LM 110/10	3033	1650	1383	230	81
8LM 110/11	3358	1775	1583	270	88
8LM 110/12	3483	1900	1583	270	94
8LM 110/13 D	3758	2025	1733	300	101
8LM 110/14 D	3883	2150	1733	300	108
8LM 110/15 D	4008	2275	1733	300	115
8LM 110/16 D	4034	2400	1634	385	125
8LM 110/17 D	4159	2525	1634	385	132
8LM 110/18 D	4284	2650	1634	385	138

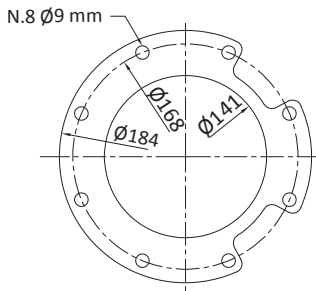

FOR COMMERCIAL TUBE  
EXTERNAL DIAMETER: 139,7 mm

Max Eff. % =	77
Max kW / St. =	7,2

Q (flow)	25%	50%	75%	100%
NPSH (m)	2,5	2,9	3,9	7,8

"D" Pump shaft in Duplex



8LM 110

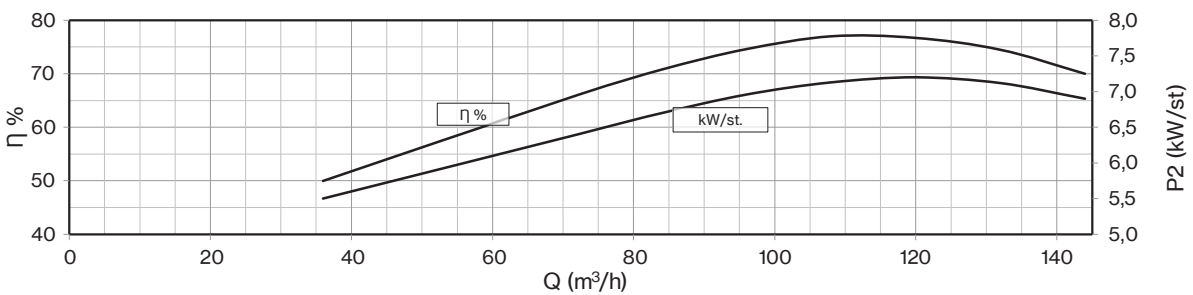
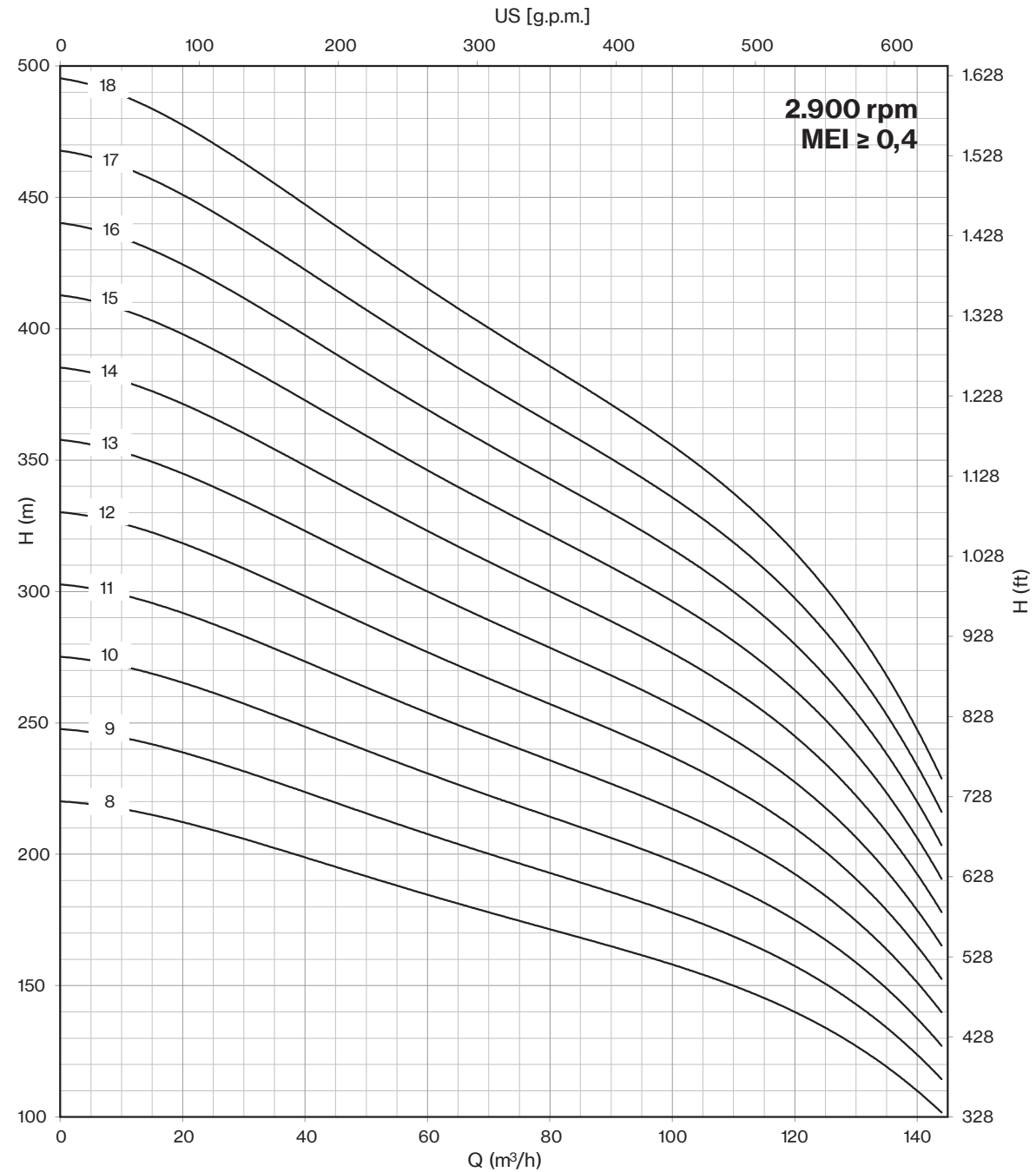

# 8LM

## 8LM 130

Motor 50 Hz - 2900 rpm				Q									
TYPE	Power		400 V	l/min l/sec m <sup>3</sup> /h	0	600	1600	1800	2000	2200	2400	2600	28
	HP	kW			A	0	10,0	26,7	30,0	33,3	36,7	40,0	43,3
					0	36	96	108	120	132	144	156	168
8LM 130/01	12,5	9,2	19,9	H[m]	27	25	21	20	19	18	16	15	12
8LM 130/02	25	18,5	38,3		54	49	41	40	38	36	33	29	24
8LM 130/03	35	26	52,9		81	74	62	59	57	54	49	44	36
8LM 130/04	50	37	75,8		108	98	83	79	76	72	66	58	48
8LM 130/05	60	45	86,3		135	123	104	99	95	90	82	73	60
8LM 130/06	75	55	106,2		162	147	124	119	114	108	98	87	72
8LM 130/07	90	66	126,0		189	172	145	139	133	126	115	102	84
8LM 130/08	100	75	143,2		216	196	166	158	152	144	131	116	96

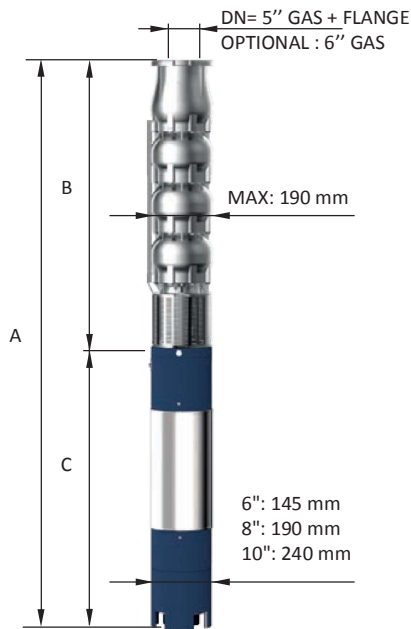

Motor 50 Hz 2900 rpm	DIMENSIONS (mm)			Weight (kg)	
TYPE	A	B	C	M	P
8LM 130/01	1214	463	751	60	19
8LM 130/02	1579	588	991	83	26
8LM 130/03	1894	713	1181	100	33
8LM 130/04	2179	838	1341	118	40
8LM 130/05	2148	1025	1123	178	48
8LM 130/06	2383	1150	1233	200	55
8LM 130/07	2577	1275	1302	214	62
8LM 130/08	2783	1400	1383	230	69

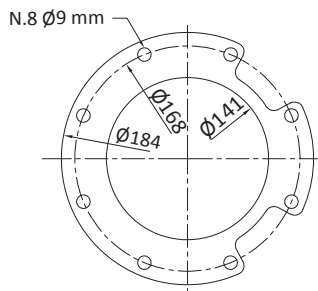

FOR COMMERCIAL TUBE  
EXTERNAL DIAMETER: 139,7 mm

Max Eff. % =	78
Max kW / St. =	8,4

Q (flow)	25%	50%	75%	100%
NPSH (m)	2,5	3	3,5	8,





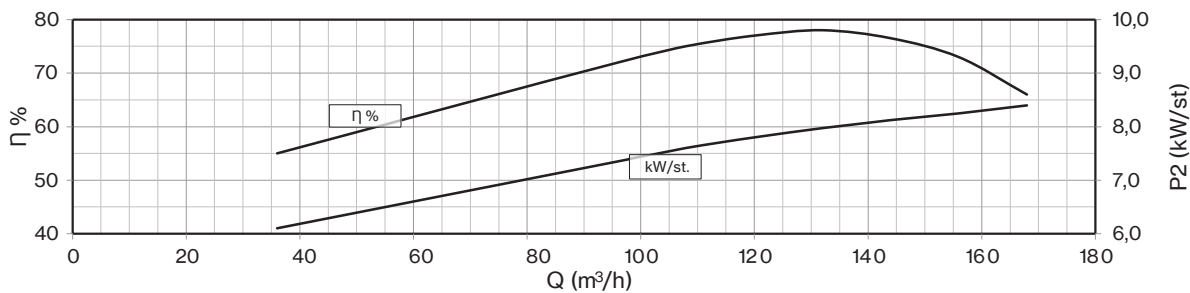
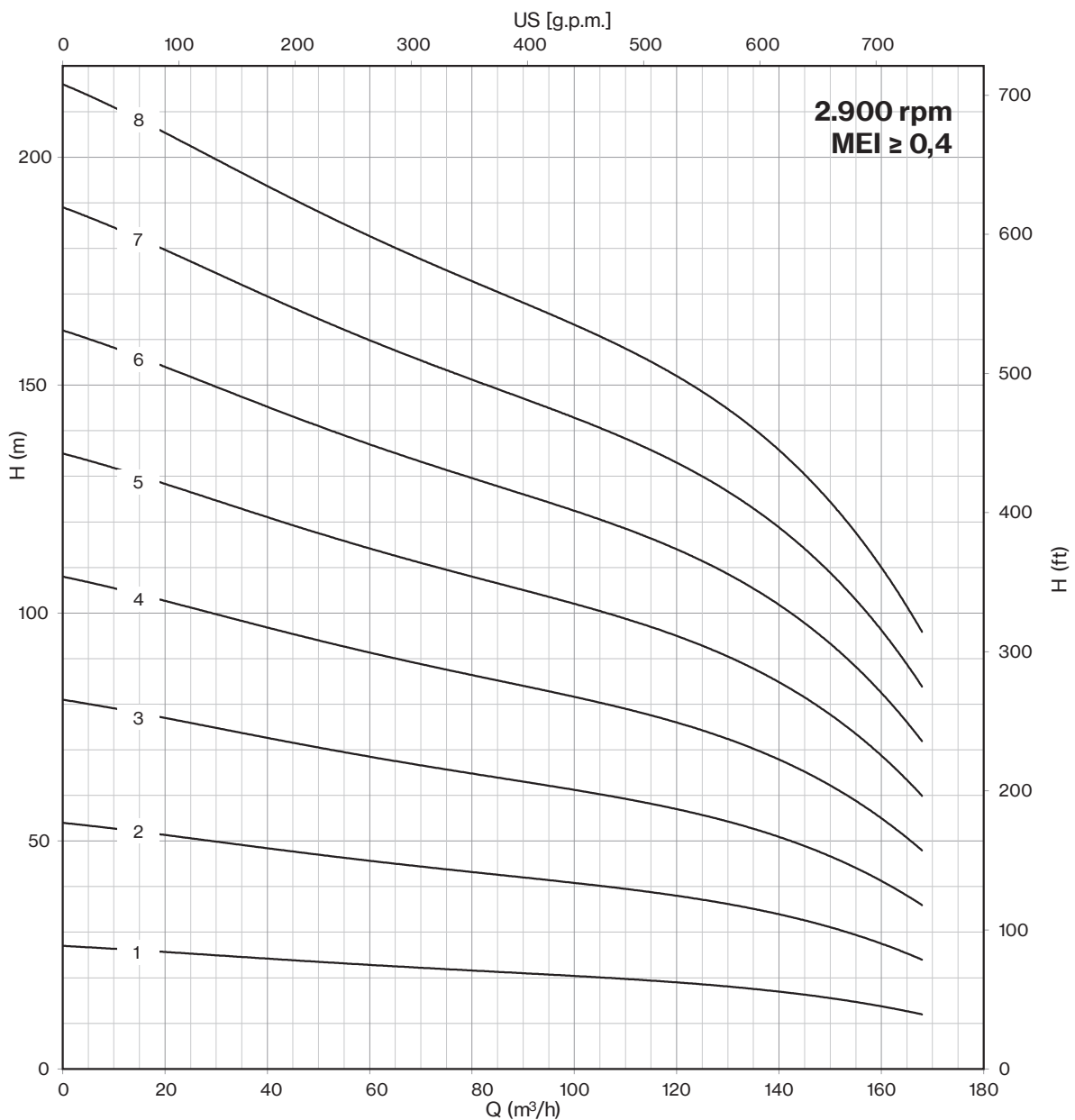

# 8LM

## 8LM 130

Motor 50 Hz - 2900 rpm				Q									
TYPE	Power		400 V	l/min l/sec m <sup>3</sup> /h	0	600	1600	1800	2000	2200	2400	2600	2800
	HP	kW			A	0	10,0	26,7	30,0	33,3	36,7	40,0	43,3
				H[m]	0	36	96	108	120	132	144	156	168
8LM 130/09	125	92	175,1	H[m]	243	221	186	178	171	162	148	131	108
8LM 130/10	125	92	175,1		270	245	207	198	190	180	164	145	120
8LM 130/11	150	110	211,0		297	270	228	218	209	198	180	160	132
8LM 130/12 D	150	110	211,0		324	294	248	238	228	216	197	174	144
8LM 130/13 D	150	110	211,0		351	319	269	257	247	234	213	189	156
8LM 130/14 D	175	130	245,3		378	343	290	277	266	252	230	203	168
8LM 130/15 D	175	130	245,3		405	368	311	297	285	270	246	218	180
8LM 130/16 D	200	150	277,2		432	392	331	317	304	288	262	232	192
8LM 130/17 D	200	150	277,2		459	417	352	337	323	306	279	247	204
8LM 130/18 D	225	165	313,3		486	441	373	356	342	324	295	261	216

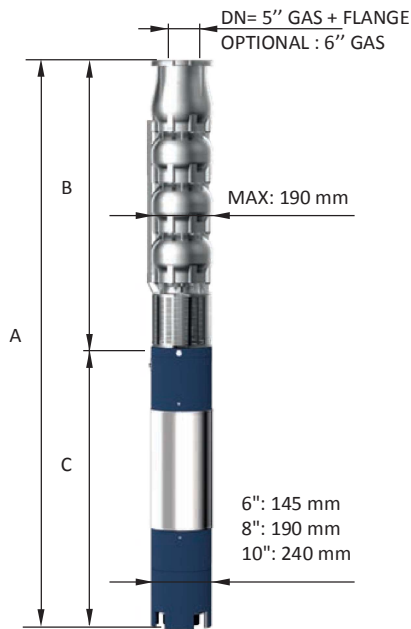

Motor 50 Hz 2900 rpm	DIMENSIONS (mm)			Weight (kg)	
TYPE	A	B	C	M	P
8LM 130/09	3108	1525	1583	270	76
8LM 130/10	3233	1650	1583	270	83
8LM 130/11	3508	1775	1733	300	90
8LM 130/12 D	3633	1900	1733	300	97
8LM 130/13 D	3758	2025	1733	300	104
8LM 130/14 D	3784	2150	1634	385	114
8LM 130/15 D	3909	2275	1634	385	121
8LM 130/16 D	4134	2400	1734	415	128
8LM 130/17 D	4259	2525	1734	415	135
8LM 130/18 D	4504	2650	1854	444	142

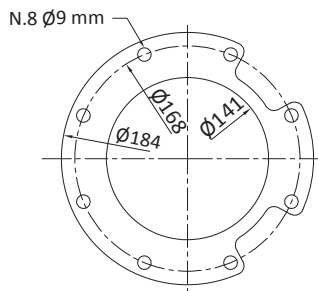

FOR COMMERCIAL TUBE  
EXTERNAL DIAMETER: 139,7 mm

Max Eff. % =	78
Max kW / St. =	8,4

Q (flow)	25%	50%	75%	100%
NPSH (m)	2,5	3	3,5	8,7

"D" Pump shaft in Duplex



8LM 130

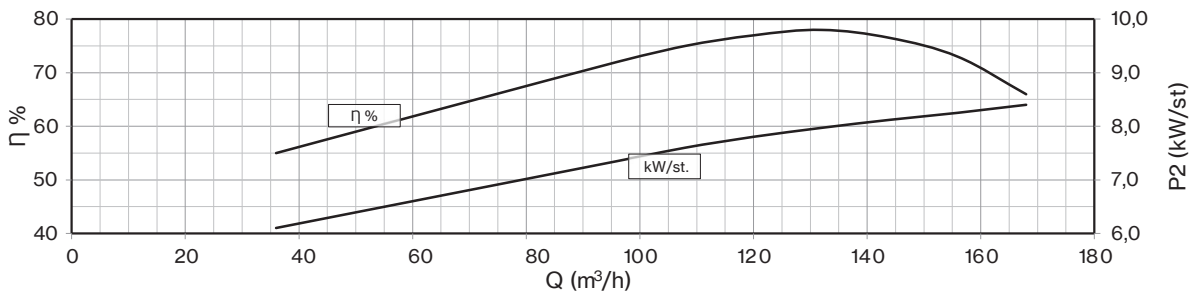
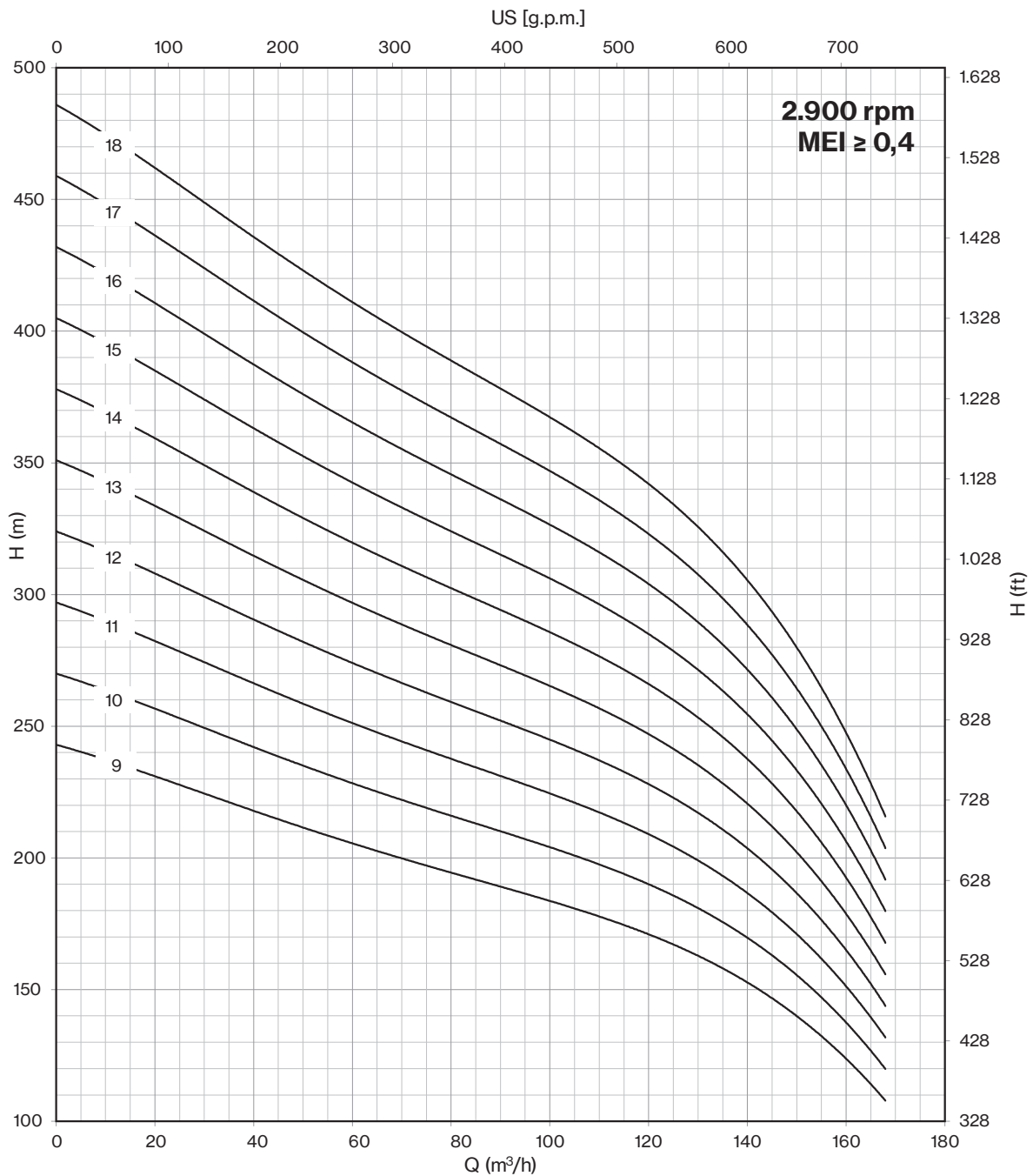

# 8LM

## 8LM 160

Motor 50 Hz - 2900 rpm				Q									
TYPE	Power		400 V	l/min l/sec m <sup>3</sup> /h	0	600	2000	2200	2400	2600	2800	3000	3200
	HP	kW			A	0	10,0	33,3	36,7	40,0	43,3	46,7	50,0
				H[m]	0	36	120	132	144	156	168	18	
8LM 160/01	15	11	23,4	H[m]	25	24	19	18	17	17	16	14	12
8LM 160/02	30	22	45,1		50	48	38	36	35	33	31	28	24
8LM 160/03	40	30	61,1		75	71	56	54	52	50	47	41	36
8LM 160/04	60	45	86,3		100	95	75	72	70	66	62	55	48
8LM 160/05	75	55	106,2		125	119	94	91	87	83	78	69	60
8LM 160/06	90	66	126,0		150	143	113	109	104	100	93	83	72
8LM 160/07	90	66	126,0		175	167	132	127	122	116	109	97	84
8LM 160/08	125	92	175,1		200	190	150	145	139	133	124	110	96

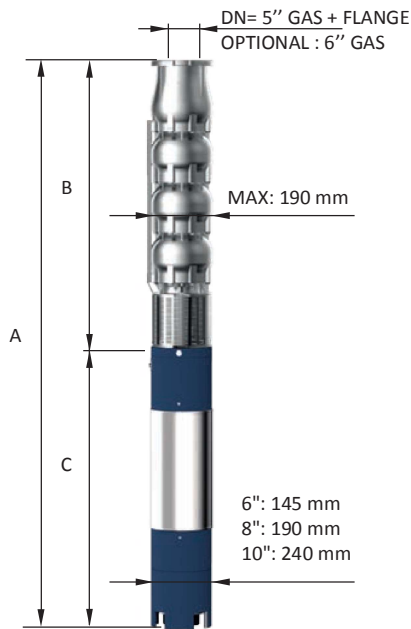

Motor 50 Hz 2900 rpm	DIMENSIONS (mm)			Weight (kg)	
TYPE	A	B	C	M	P
8LM 160/01	1299	488	811	65	20
8LM 160/02	1709	638	1071	92	27
8LM 160/03	2039	788	1251	108	35
8LM 160/04	2061	938	1123	178	42
8LM 160/05	2383	1150	1233	200	50
8LM 160/06	2602	1300	1302	214	58
8LM 160/07	2752	1450	1302	214	65
8LM 160/08	3183	1600	1583	270	73

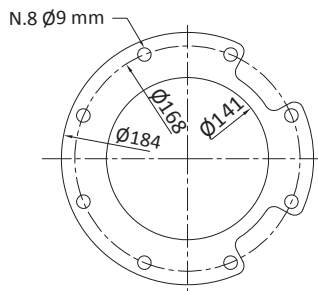

FOR COMMERCIAL TUBE  
EXTERNAL DIAMETER: 139,7 mm

Max Eff. % =	78,5
Max kW / St. =	9,4

Q (flow)	25%	50%	75%	100%
NPSH (m)	4	4,5	7	



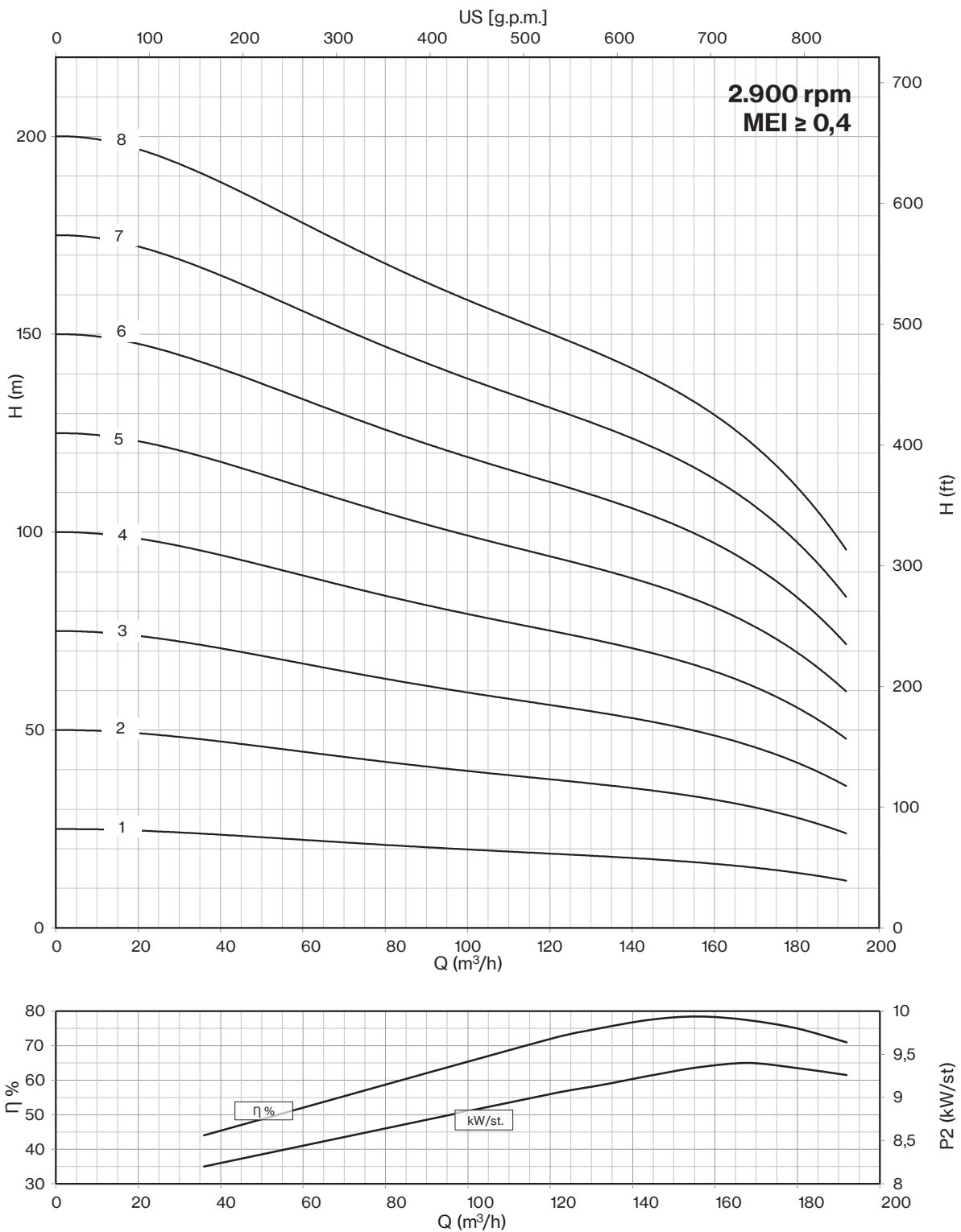

# 8LM

## 8LM 160

Motor 50 Hz - 2900 rpm				Q									
TYPE	Power		400 V	l/min l/sec m <sup>3</sup> /h	0	600	2000	2200	2400	2600	2800	3000	3200
	HP	kW			A	0	10,0	33,3	36,7	40,0	43,3	46,7	50,0
				H[m]	0	36	120	132	144	156	168	180	19
8LM 160/09	125	92	175,1	H[m]	225	214	169	163	157	149	140	124	108
8LM 160/10 D	150	110	211,0		250	238	188	181	174	166	155	138	120
8LM 160/11 D	150	110	211,0		275	262	207	199	191	183	171	152	132
8LM 160/12 D	175	130	245,3		300	286	226	217	209	199	186	166	144
8LM 160/13 D	175	130	245,3		325	309	244	235	226	216	202	179	156
8LM 160/14 D	200	150	277,2		350	333	263	253	244	232	217	193	168
8LM 160/15 D	200	150	277,2		375	357	282	272	261	249	233	207	180
8LM 160/16 D	225	165	313,3		400	381	301	290	278	266	248	221	192
8LM 160/17 D	225	165	313,3		425	405	320	308	296	282	264	235	204
8LM 160/18 D	250	185	342,2		450	428	338	326	313	299	279	248	216

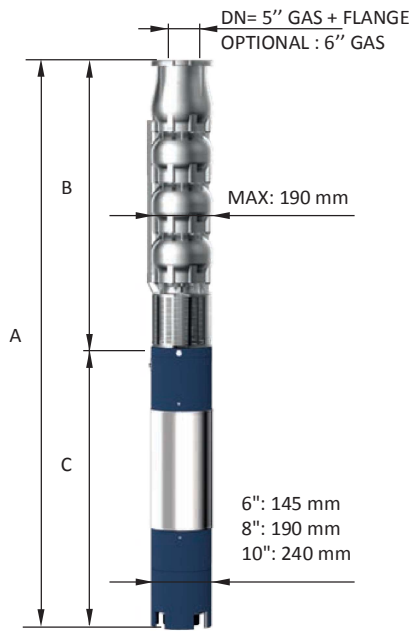

Motor 50 Hz 2900 rpm	DIMENSIONS (mm)			Weight (kg)	
	A	B	C	M	P
8LM 160/09	3333	1750	1583	270	80
8LM 160/10 D	3633	1900	1733	300	88
8LM 160/11 D	3783	2050	1733	300	95
8LM 160/12 D	3834	2200	1634	385	103
8LM 160/13 D	3984	2350	1634	385	114
8LM 160/14 D	4234	2500	1734	415	121
8LM 160/15 D	4384	2650	1734	415	129
8LM 160/16 D	4654	2800	1854	444	136
8LM 160/17 D	4804	2950	1854	444	144
8LM 160/18 D	5084	3100	1984	480	151

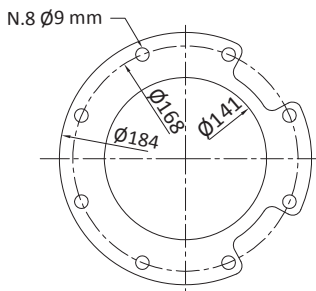

FOR COMMERCIAL TUBE  
EXTERNAL DIAMETER: 139,7 mm

Max Eff. % =	78,5
Max kW / St. =	9,4

Q (flow)	25%	50%	75%	100%
NPSH (m)	4	4,5	7	13

"D" Pump shaft in Duplex



8LM 160

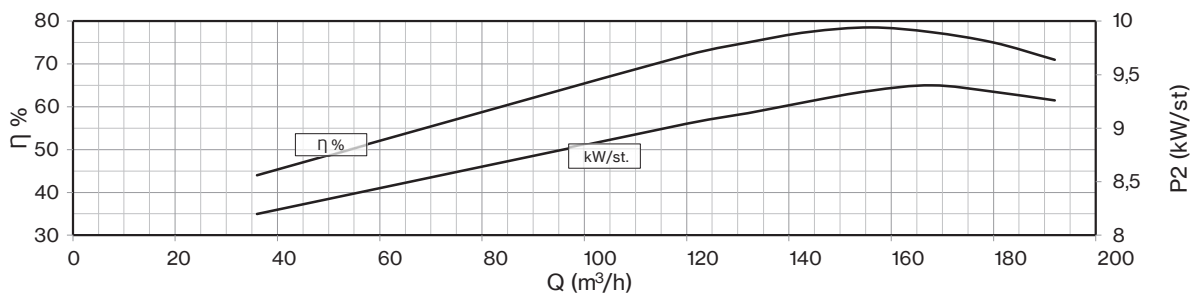
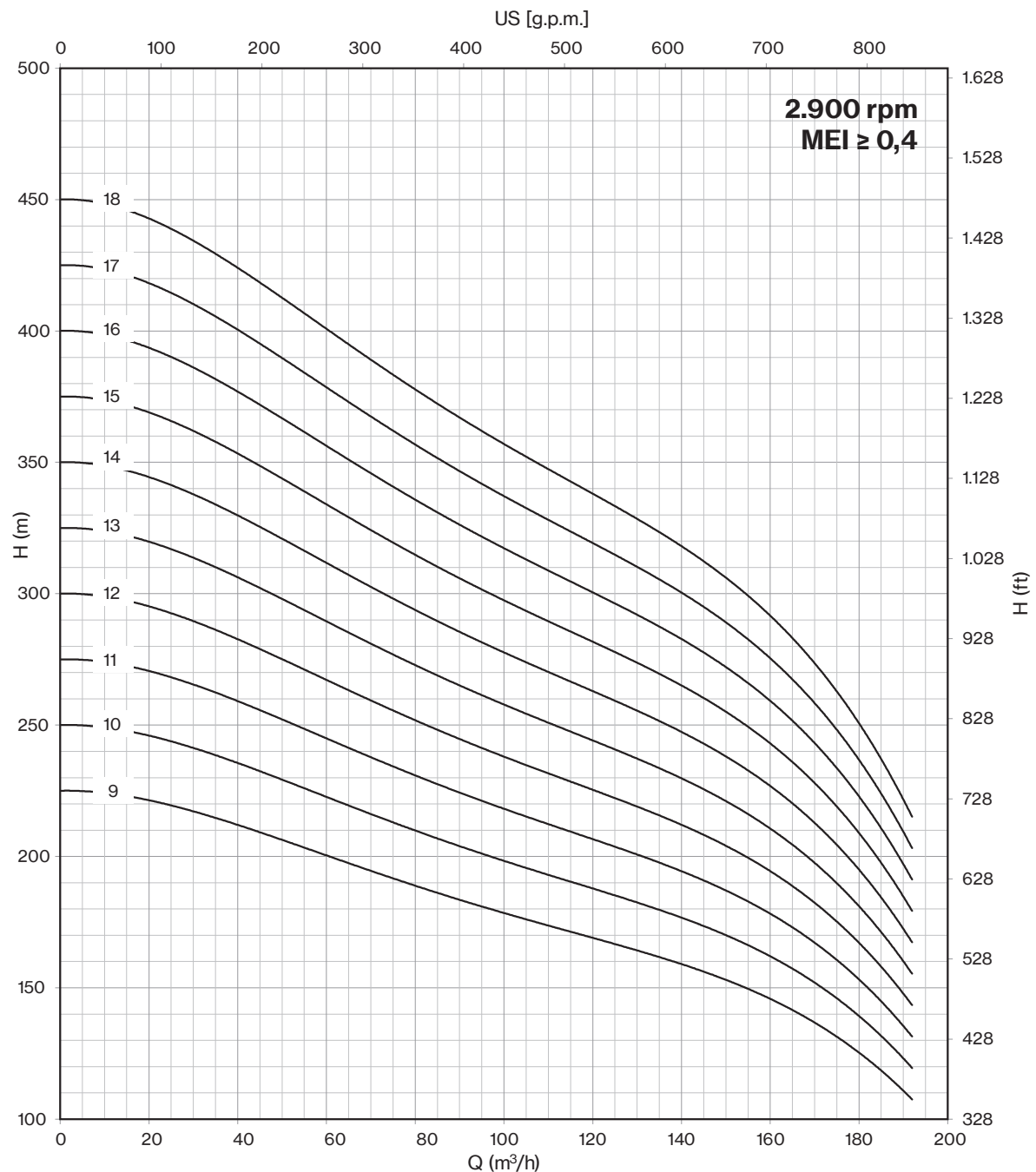

# 6LM - 8LM - 10LM - 12LM

## 6LM - 8LM - 10LM - 12LM lines

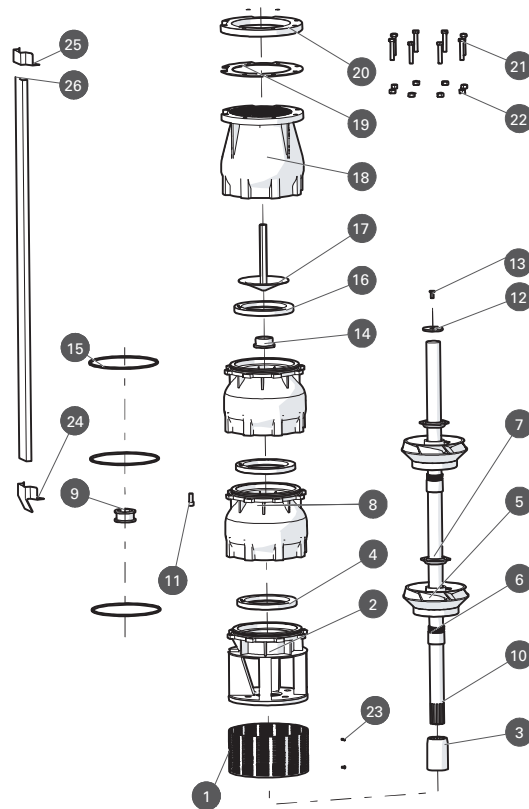

N° Code	Description	LMS Execution	LMX Execution	LMD Execution	(*) Q.ty
1	Suction strainer	AISI 304	AISI 316	Duplex	-
2	Suction cage	AISI 304	AISI 316	Duplex	-
3	Joint	AISI 304	AISI 316	Duplex	1
4	Usury ring	NBR	NBR	NBR	N° of St.
5	Impeller	AISI 304	AISI 316	Duplex	-
6	Cone	AISI 304	AISI 316	Duplex	N° of St.
7	Hexagonal ring	AISI 304	AISI 316	Duplex	N° of St.
8	Diffuseur	AISI 304	AISI 316	Duplex	-
9	Bearing bush	NBR	NBR	NBR	N° of St.
10	Pump shaft	AISI 304	AISI 316	Duplex	1
11	N.8 Screw for diffuseur	AISI 304	AISI 316	Duplex	-
12	Ring	AISI 304	AISI 316	Duplex	1
13	Screw for disk	AISI 304	AISI 316	Duplex	1
14	Counterthrust	PTFE + 25% CARBON	PTFE + 25% CARBON	PTFE + 25% CARBON	1
15	O-Ring	NBR	NBR	NBR	N° of St.
16	Gasket valve	NBR	NBR	NBR	1
17	Cap valve	AISI 304	AISI 316	Duplex	-
18	Body valve	AISI 304	AISI 316	Duplex	-
19	Seal counterflange	NBR	NBR	NBR	1
20	Counterflange	AISI 304	AISI 316	Duplex	-
21	N.8 Screw for counterflange	AISI 304	AISI 316	Duplex	-
22	N.8 Nut for counterflange	AISI 304	AISI 316	Duplex	-
23	N.2 Screw for suction strainer	AISI 304	AISI 316	Duplex	-
24	Lower clamp	AISI 304	AISI 316	Duplex	-
25	Upper clamp	AISI 304	AISI 316	Duplex	-
26	Cover cable	AISI 304	AISI 316	Duplex	-

\* Reccomended spare parts quantity

