

**50Hz**



# **GENERAL CATALOGUE**

**Edition 2022**

[www.pentax-pumps.it](http://www.pentax-pumps.it)

# Where there's water there's Pentax



Viale dell'Industria, 1  
37040 Veronella (VR) - Italia  
Tel. +39 0442 489500  
Fax +39 0442 489510  
com@pentax-pumps.it  
[www.pentax-pumps.it](http://www.pentax-pumps.it)

**PENTAX s.p.a.**



# 10-12LM & E14 lines

Deepwell Borehole

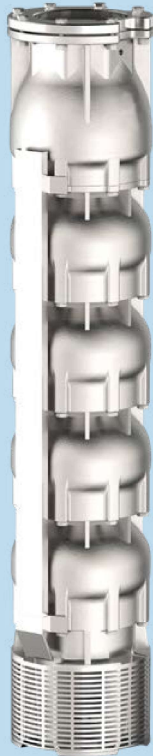

10LM line



12LM line



E14

Submersible multistage centrifugal pumps for 10", 12" and 14" wells. Check valve built into the delivery outlet. Pump flange for coupling with motors are made according to NEMA standards. Most common applications are civil and agricultural. All components are made of stainless steel with lost wax Microfusion technology. The standard material is AISI 304 stainless steel, alternatively the following materials are available on request: AISI 316 Steel, Duplex steel, AISI 904L Steel. Bushing bearings and wear-rings made of sand abrasion-resistant rubber, reverse-Thrust ring in PTFE/Graphite.

#### General operating data:

- Capacity up to 860 m<sup>3</sup>/h
- Pressure up to 800 m
- Hydraulic efficiency 10", up to 84,0%
- Hydraulic efficiency 12", up to 82,5%
- Hydraulic efficiency 14", up to 82,3%
- Pressure up to 80 bar
- Powers up to 400 kW
- Rotation speed up to 3600 rpm
- Maximum depth: 350 m
- Maximum quantity of permitted sand: 100 gr/m<sup>3</sup>
- Drinking water compatibility according to DM174 MEI >= 0,4 (EU directive No.547/2012)
- Performance tolerance: ISO9906-3B.

#### Construction features

<b>Suction and delivery outlet</b>	AISI 304 (LMS) AISI 316 (LMX - EX) Duplex (LMD - ED) Cast iron (E)
<b>Valve</b>	AISI 304 (LMS) AISI 316 (LMX - EX) Duplex (LMD - ED) Cast iron (E)
<b>Impellers and diffusers</b>	AISI 304 (LMS) AISI 316 (LMX - EX) Duplex (LMD - ED) Cast iron (E)
<b>Upper bushings</b>	NBR rubber
<b>Shaft pump side</b>	AISI 304 (LMS) AISI 316 (LMX) Duplex (LMD) AISI 431 (E - EX - ED)
<b>Quantity of sand in the water</b>	max 100 g/m <sup>3</sup>

#### Motor

<b>Asynchronous 2 pole</b>	rewindable water cooled
<b>Insulation class</b>	Y (max 30 °C) - PPC winding type F (max 50 °C) - PE2+PA or LPE winding type
<b>Protection degree</b>	IP68
<b>Liquid temperature</b>	max 30 °C (max 50 °C on request)
<b>Depth of immersion</b>	max 350 m



12LM 360

Motor 50 Hz - 2900 rpm				Q									
TYPE	Power		400 V	l/min	0	1500	4000	4500	5000	5500	6000	6500	7000
	HP	kW		l/sec	0	25,0	66,7	75,0	83,3	91,7	100,0	108,3	116,7
	A	m <sup>3</sup> /h	0	90	240	270	300	330	360	390	420		
12LM 360/01 DR35	50	37	75,8	H[m]	41	40	37	35	33	32	29		
12LM 360/01 DR20	75	55	106,2		49	48	47	45	44	42	40	38	34
12LM 360/01	90	66	126,0		62	61	55	53	52	52	50	47	42
12LM 360/02 DR35	100	75	143,2		82	80	73	70	66	63	57		
12LM 360/02 DR20 D	150	110	211,0		98	96	93	90	87	84	80	75	68
12LM 360/02 D	175	130	245,3		124	122	109	106	104	103	100	93	84
12LM 360/03 DR20 D	200	150	277,2		147	144	140	135	131	126	120	113	102
12LM 360/03 DR10 D	250	185	342,2		165	162	152	149	144	140	132	126	120
12LM 360/03 D	300	220	430,0		186	183	164	159	156	155	150	140	126
12LM 360/04 DR20 D	300	220	430,0		196	192	186	180	174	168	160	150	136
12LM 360/04 DR10 D	340	250	481,0		220	216	202	198	192	186	176	168	160
12LM 360/04 D	400	300	551,0		248	244	218	212	208	206	200	186	168

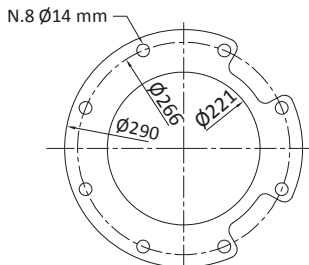
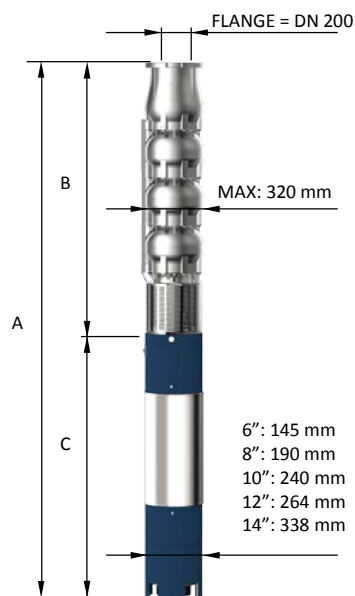

FOR COMMERCIAL TUBE  
EXTERNAL DIAMETER: 219,1 mm

Motor 50 Hz 2900 rpm	DIMENSIONS (mm)			Weight (kg)	
TYPE	A	B	C	M	P
12LM 360/01 DR35	2111	770	1341	118	79
12LM 360/01 DR20	2003	770	1233	200	79
12LM 360/01	2072	770	1302	214	79
12LM 360/02 DR35	2383	1000	1383	230	104
12LM 360/02 DR20 D	2733	1000	1733	300	104
12LM 360/02 D	2634	1000	1634	385	104
12LM 360/03 DR20 D	2964	1230	1734	415	129
12LM 360/03 DR10 D	3214	1230	1984	480	129
12LM 360/03 D	3340	1230	2110	700	129
12LM 360/04 DR20 D	3570	1460	2110	700	154
12LM 360/04 DR10 D	3740	1460	2280	775	154
12LM 360/04 D	3740	1460	2280	775	154

Max Eff. % DR35 =	77,5
Max Eff. % DR20 =	80
Max Eff. % DR10 =	80,5
Max Eff. % =	81
Max kW / St. DR35 =	36,80
Max kW / St. DR20 =	49,5
Max kW / St. DR10 =	55,2
Max kW / St. =	64,2

Q (flow)	25%	50%	75%	100%
NPSH (m)	3,4	5	7,8	11,8

"D" Pump shaft in Duplex



12LM 360

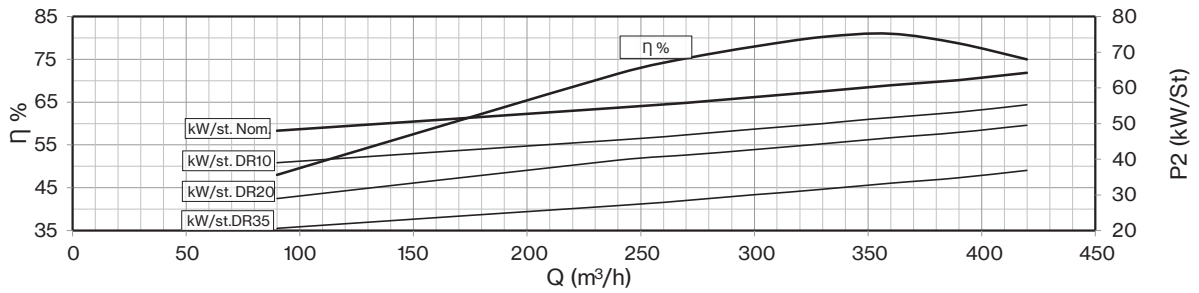
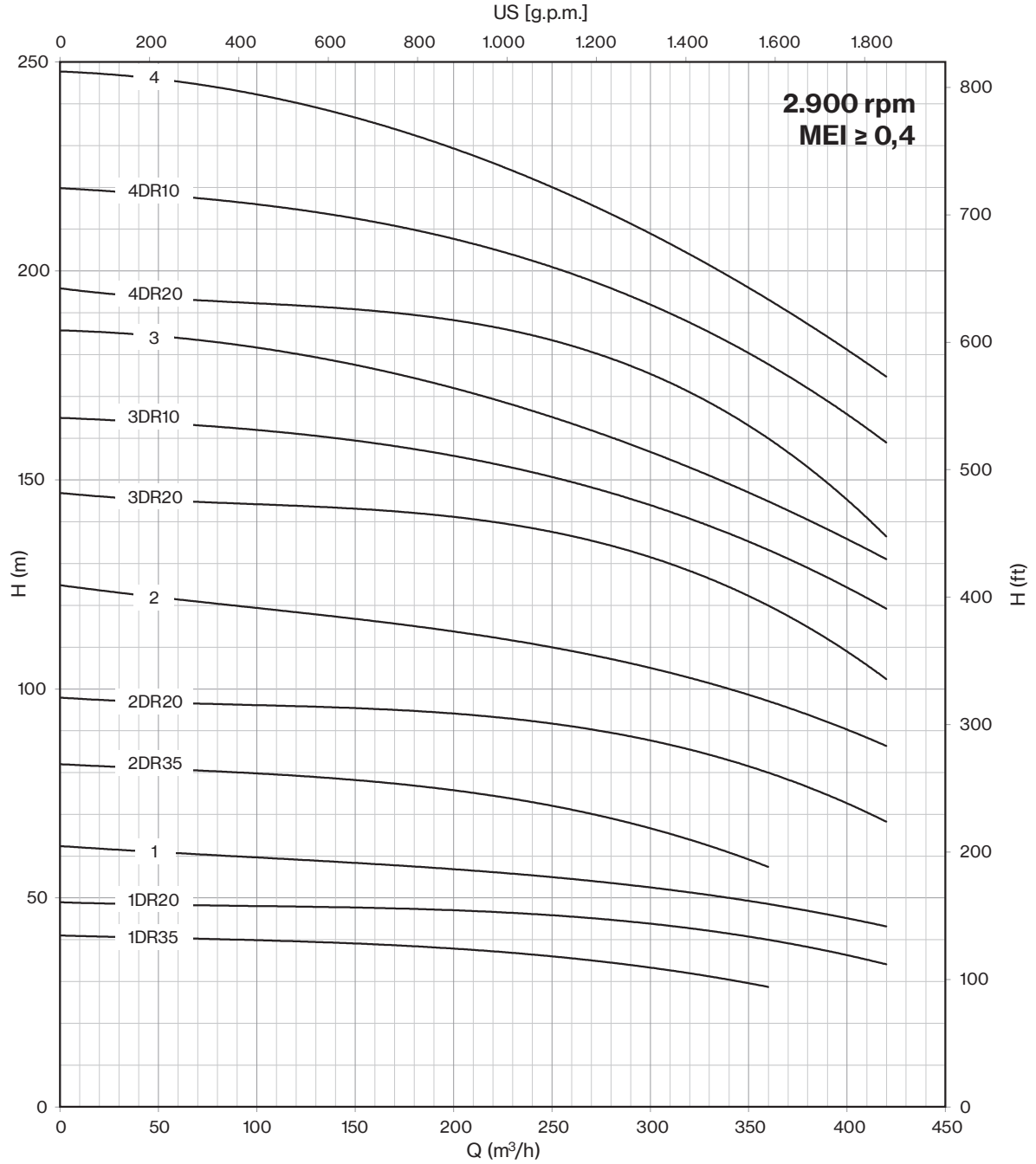

12LM 360

Motor 50 Hz - 2900 rpm				Q									
TYPE	Power		400 V	l/min	0	1500	4000	4500	5000	5500	6000	6500	7000
	HP	kW		l/sec	0	25,0	66,7	75,0	83,3	91,7	100,0	108,3	116,7
	A	m <sup>3</sup> /h	0	90	240	270	300	330	360	390	420		
12LM 360/05 DR20 D	340	250	481,0	H[m]	245	240	233	225	218	210	200	188	170
12LM 360/05 DR10 D	400	300	551,0		275	270	253	248	240	233	220	210	200
12LM 360/05 D	450	330	620,0		310	305	273	265	260	258	250	233	210
12LM 360/06 DR10 D	500	370	693,0		330	324	304	298	288	280	264	252	240
12LM 360/06 D	550	400	798,0		372	366	328	318	312	310	300	280	252
12LM 360/07 DR10 D	550	400	798,0		385	378	354	347	336	326	308	294	280

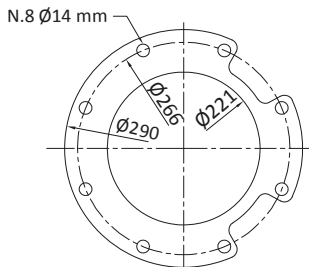
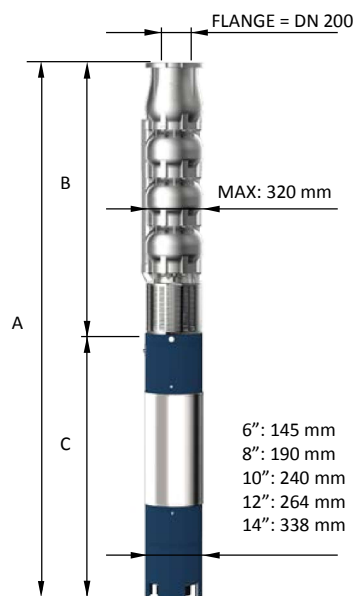

FOR COMMERCIAL TUBE  
EXTERNAL DIAMETER: 219,1 mm

Motor 50 Hz 2900 rpm	DIMENSIONS (mm)			Weight (kg)	
TYPE	A	B	C	M	P
12LM 360/05 DR20 D	3970	1690	2280	775	179
12LM 360/05 DR10 D	3970	1690	2280	775	179
12LM 360/05 D	3850	1690	2160	906	179
12LM 360/06 DR10 D	4240	1920	2320	1010	204
12LM 360/06 D	4380	1920	2460	1105	204
12LM 360/07 DR10 D	4610	2150	2460	1105	229

Max Eff. % DR35 =	77,5
Max Eff. % DR20 =	80
Max Eff. % DR10 =	80,5
Max Eff. % =	81
Max kW / St. DR35 =	36,80
Max kW / St. DR20 =	49,5
Max kW / St. DR10 =	55,2
Max kW / St. =	64,2

Q (flow)	25%	50%	75%	100%
NPSH (m)	3,4	5	7,8	11,8

"D" Pump shaft in Duplex



12LM 360

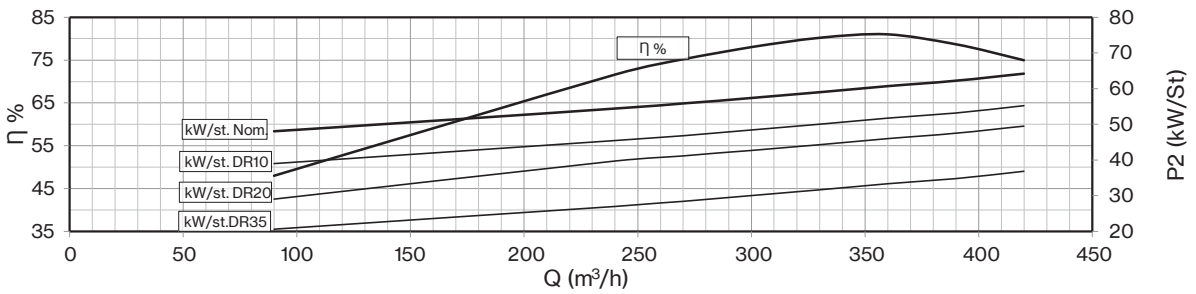
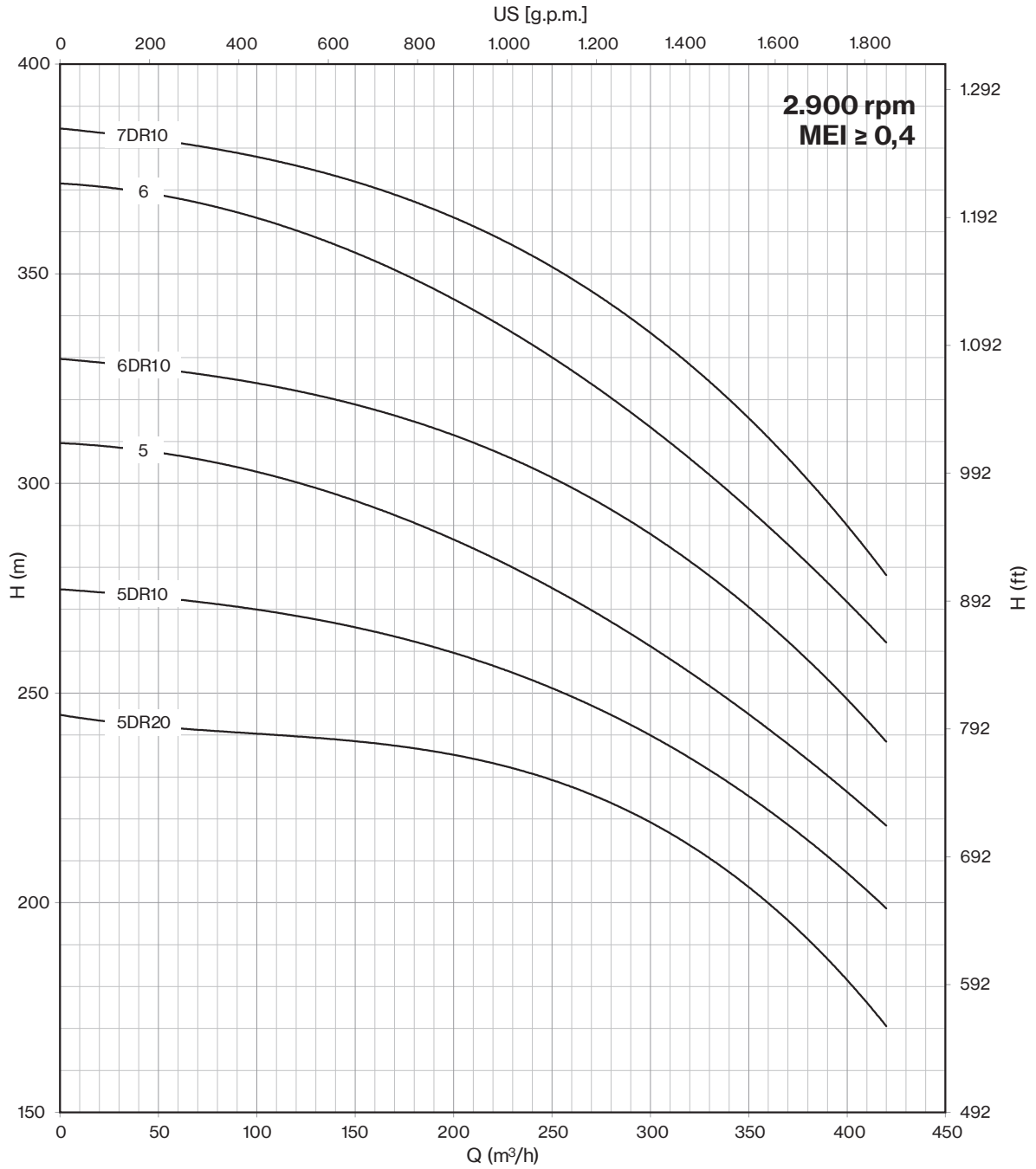

12LM 400

Motor 50 Hz - 2900 rpm				Q									
TYPE	Power		400 V	l/min	0	2000	6000	6500	7000	7500	8000	8500	90
	HP	kW		l/sec	0	33,3	100,0	108,3	116,7	125,0	133,3	141,	
	A	m <sup>3</sup> /h	0	120	360	390	420	450	480	510	5		
12LM 400/01 DR30	50	37	75,8	H[m]	43	42	32	30	27	24			
12LM 400/01 DR20	75	55	106,2		47	45	37	35	33	30	26	22	
12LM 400/01 DR10	75	55	106,2		53	52	42	40	38	36	32	28	
12LM 400/01	90	66	126,0		58	57	46	44	42	40	37	31	27
12LM 400/02 DR30	100	75	143,2		86	84	64	59	54	48			
12LM 400/02 DR20	125	92	175,1		94	90	73	69	65	59	52	44	
12LM 400/02 DR10 D	150	110	211,0		106	104	84	80	76	71	64	56	
12LM 400/02 D	175	130	245,3		116	114	92	88	84	80	73	62	54
12LM 400/03 DR20 D	200	150	277,2		141	135	110	104	98	89	78	66	
12LM 400/03 DR10 D	225	165	313,3		159	156	126	120	114	107	96	84	
12LM 400/03 D	250	185	342,2		174	171	138	132	126	120	110	93	81

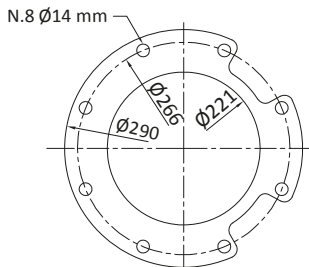
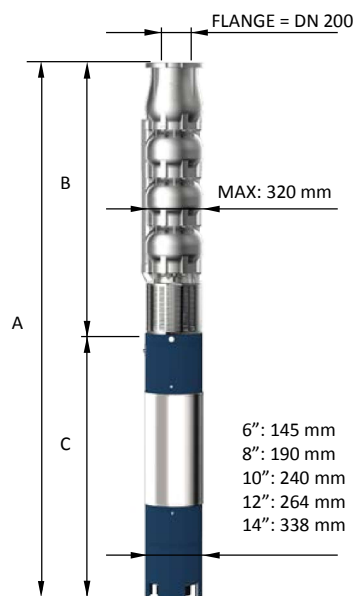

FOR COMMERCIAL TUBE  
EXTERNAL DIAMETER: 219,1 mm

Motor 50 Hz 2900 rpm	DIMENSIONS (mm)			Weight (kg)	
TYPE	A	B	C	M	P
12LM 400/01 DR30	2111	770	1341	118	79
12LM 400/01 DR20	2003	770	1233	200	79
12LM 400/01 DR10	2003	770	1233	200	79
12LM 400/01	2072	770	1302	214	79
12LM 400/02 DR30	2383	1000	1383	230	104
12LM 400/02 DR20	2583	1000	1583	270	104
12LM 400/02 DR10 D	2733	1000	1733	300	104
12LM 400/02 D	2634	1000	1634	385	104
12LM 400/03 DR20 D	2964	1230	1734	415	129
12LM 400/03 DR10 D	3084	1230	1854	444	129
12LM 400/03 D	3214	1230	1984	480	129

Max Eff. % DR30 =	81,2
Max Eff. % DR20 =	81,8
Max Eff. % DR10 =	82,7
Max Eff. % =	81,6
Max Eff. % A =	82,5
Max kW / St. DR30 =	37
Max kW / St. DR20 =	45,6
Max kW / St. DR10 =	53
Max kW / St. =	60,4
Max kW / St. A =	67

Q (flow)	25%	50%	75%	100%
NPSH (m)	3,4	5	7,8	11,

"D" Pump shaft in Duplex





12LM 400

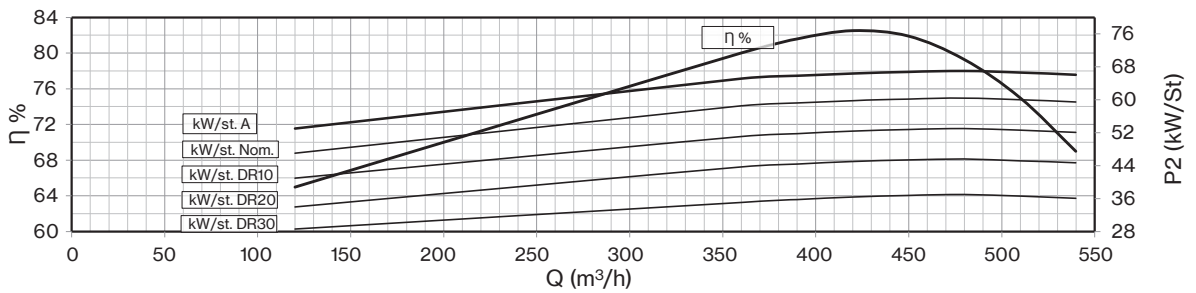
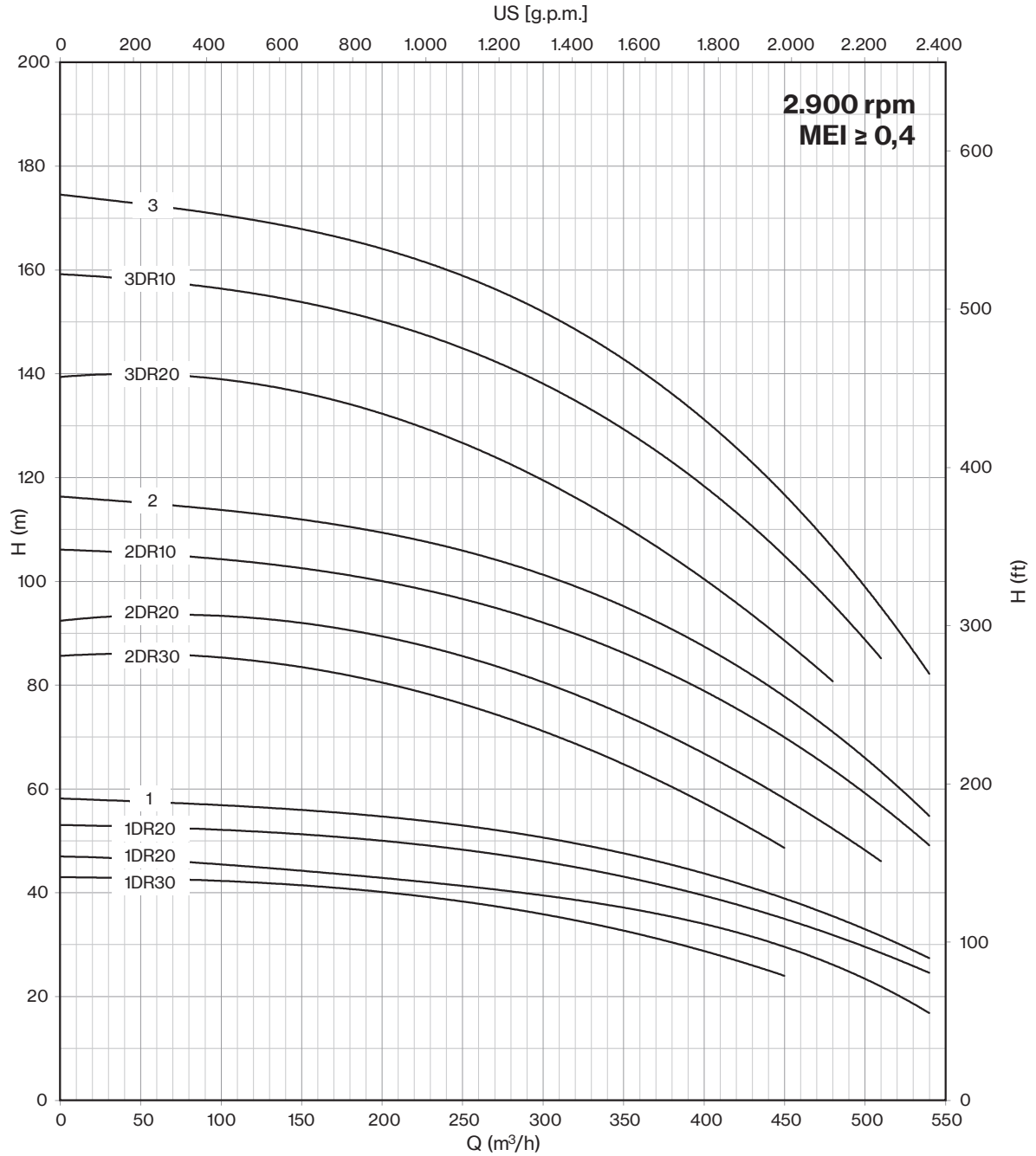

12LM 400

Motor 50 Hz - 2900 rpm				Q									
TYPE	Power		400 V	l/min	0	2000	6000	6500	7000	7500	8000	8500	9000
	HP	kW		l/sec	0	33,3	100,0	108,3	116,7	125,0	133,3	141,7	150,0
	A	m <sup>3</sup> /h	0	120	360	390	420	450	480	510	54		
12LM 400/04 DR20 D	250	185	342,2	H[m]	188	180	146	138	130	118	104	88	
12LM 400/04 DR10 D	300	220	430,0		212	208	168	160	152	142	128	112	
12LM 400/04 D	340	250	481,0		232	228	184	176	168	160	146	124	108
12LM 400/05 DR10 D	400	300	551,0		265	260	210	200	190	178	160	140	
12LM 400/05 D	450	330	620,0		290	285	230	220	210	200	183	155	135
12LM 400/05A D	500	370	693,0		305	300	250	240	230	223	205	195	160
12LM 400/06 D	500	370	693,0		348	342	276	264	252	240	220	186	162

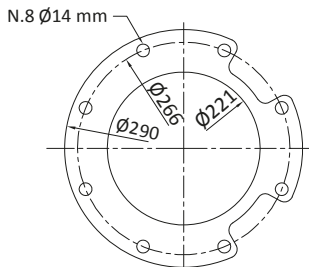
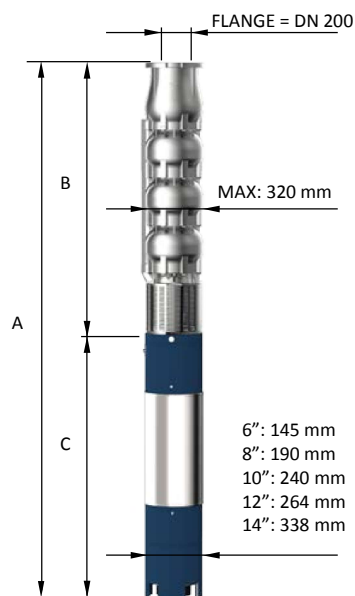

FOR COMMERCIAL TUBE  
EXTERNAL DIAMETER: 219,1 mm

Motor 50 Hz 2900 rpm	DIMENSIONS (mm)			Weight (kg)	
TYPE	A	B	C	M	P
12LM 400/04 DR20 D	3444	1460	1984	480	154
12LM 400/04 DR10 D	3570	1460	2110	700	154
12LM 400/04 D	3740	1460	2280	775	154
12LM 400/05 DR10 D	3970	1690	2280	775	179
12LM 400/05 D	3850	1690	2160	906	179
12LM 400/05A D	4010	1690	2320	1010	179
12LM 400/06 D	4240	1920	2320	1010	204

Max Eff. % DR30 =	81,2
Max Eff. % DR20 =	81,8
Max Eff. % DR10 =	82,7
Max Eff. % =	81,6
Max Eff. % A =	82,5
Max kW / St. DR30 =	37
Max kW / St. DR20 =	45,6
Max kW / St. DR10 =	53
Max kW / St. =	60,4
Max kW / St. A =	67

Q (flow)	25%	50%	75%	100%
NPSH (m)	3,4	5	7,8	11,

"D" Pump shaft in Duplex



12LM 400

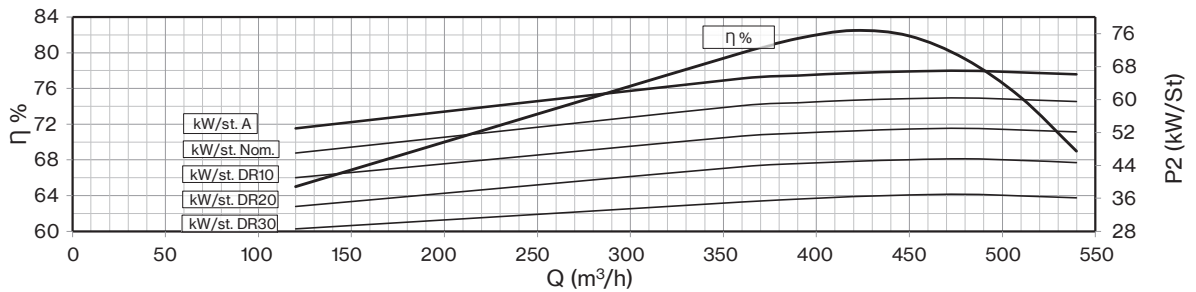
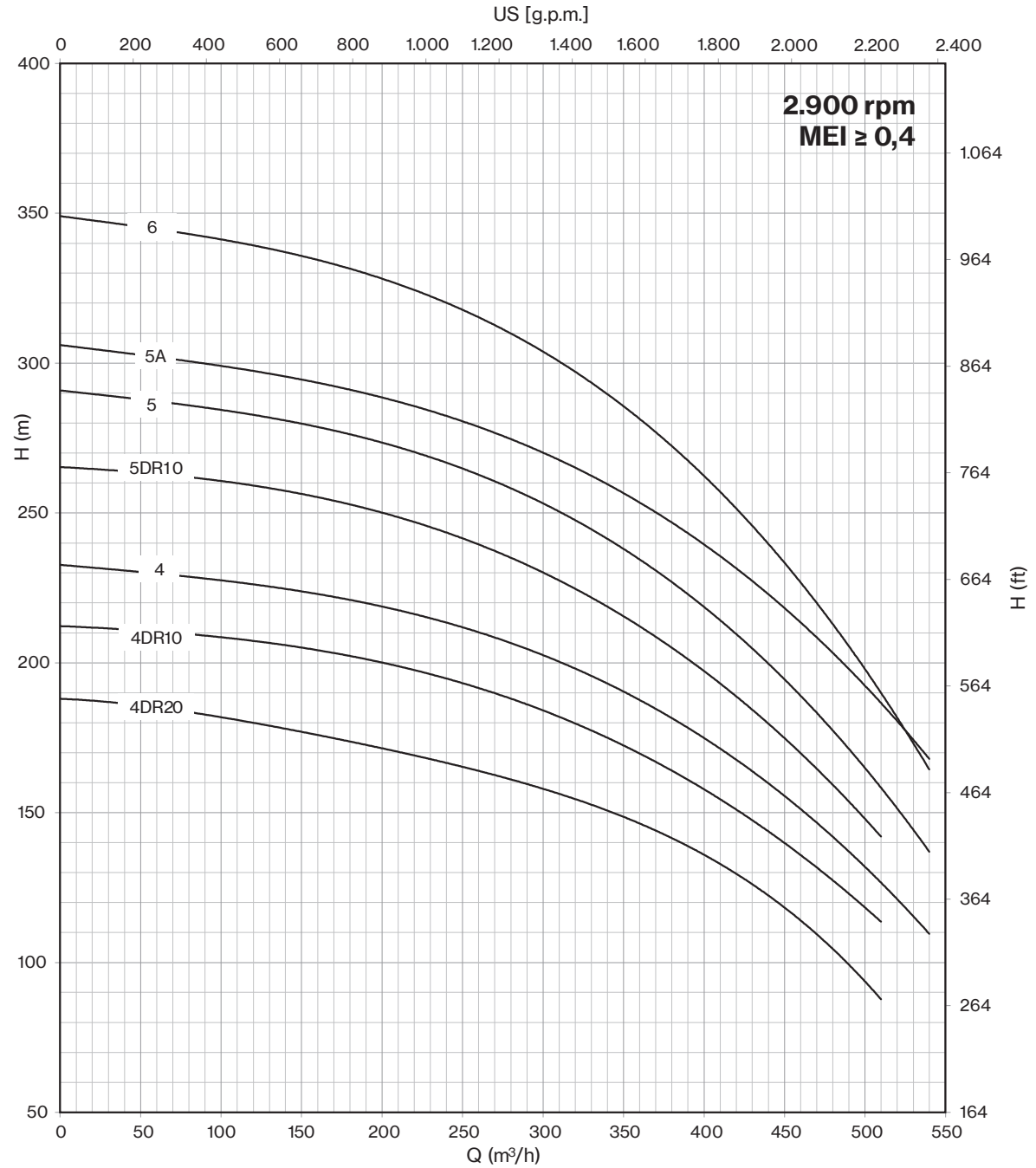

Motor 50 Hz - 2900 rpm				Q									
TYPE	Power		400 V A	l/min l/sec m <sup>3</sup> /h	0	1333	2667	4000	5333	6667	8000	8500	966
	HP	kW			0	22,2	44,5	66,7	88,9	111,1	133,3	141,8	161,2
					0	80	160	240	320	400	480	510	58
E 14 A/1 D	90	66	126,0	H[m]	71,8	66,5	62,5	58,7	54,4	49,0	41,6	38,2	
E 14 A/1 C	100	75	143,2		76,8	71,7	67,5	63,8	59,6	54,6	47,9	45,0	39,0
E 14 A/1 B	125	92	175,1		85,1	79,9	75,6	71,8	67,8	63,3	57,7	55,1	48,2
E 14 A/1 A	150	110	211,0		97,1	90,8	85,5	80,4	75,6	70,7	65,4	63,0	57,6
E 14 A/1 Nom.	175	130	245,3		108,6	99,3	92,3	87,0	82,5	78,0	73,0	70,8	64,1
E 14 A/2 D	175	130	245,3		143,5	133,0	125,0	117,4	108,8	98,0	83,2	76,4	
E 14 A/2 C	200	150	277,2		153,6	143,4	135,0	127,6	119,1	109,1	95,8	90,0	78,0
E 14 A/2 B	250	185	342,2		170,2	159,8	151,2	143,6	135,6	126,5	115,4	110,2	96,4
E 14 A/2 A	300	220	430,0		194,3	181,6	171,0	160,8	151,2	141,4	130,8	126,0	115,2
E 14 A/2 Nom.	340	250	481,0		217,3	198,6	184,6	174,0	165,0	156,0	146,0	141,6	128,2

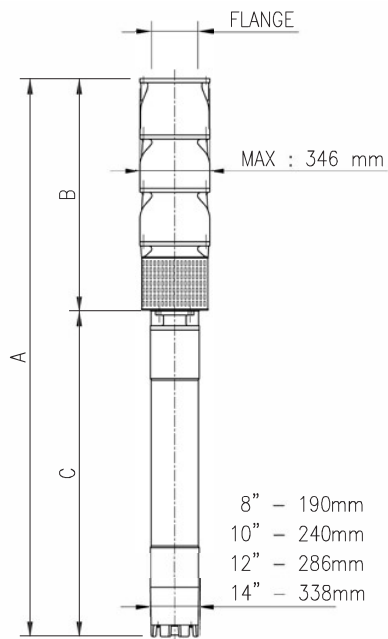

Motor 50 Hz 2900 rpm	DIMENSIONS (mm)			Weight (kg)	
TYPE	A	B	C	M	P
E 14 A/1 D	2237	935	1302	214	184
E 14 A/1 C	2318	935	1383	230	184
E 14 A/1 B	2518	935	1583	270	184
E 14 A/1 A	2668	935	1733	300	184
E 14 A/1 Nom.	2569	935	1634	385	184
E 14 A/2 D	2809	1175	1634	385	260
E 14 A/2 C	2909	1175	1734	415	260
E 14 A/2 B	3159	1175	1984	480	260
E 14 A/2 A	3285	1175	2110	700	260
E 14 A/2 Nom.	3455	1175	2280	775	260

Max Eff. % =	82,3
Max KW / St.: D = - D.230mm =	64,9
Max KW / St.: C = - D.238mm =	74,0
Max KW / St.: B = - D.251mm =	90,8
Max KW / St. A = - D.268mm =	109,1
Max KW / St. Nom. - D.276mm =	119,3

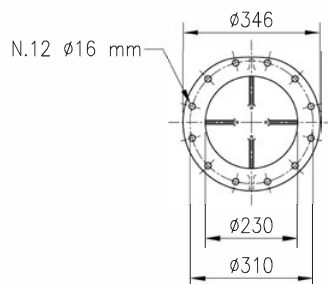

Q (flow)	25%	50%	75%	100%
NPSH (m)	5,8	6,4	9,4	15,3

"D" Pump shaft in Duplex



# 6LM - 8LM - 10LM - 12LM

## 6LM - 8LM - 10LM - 12LM lines

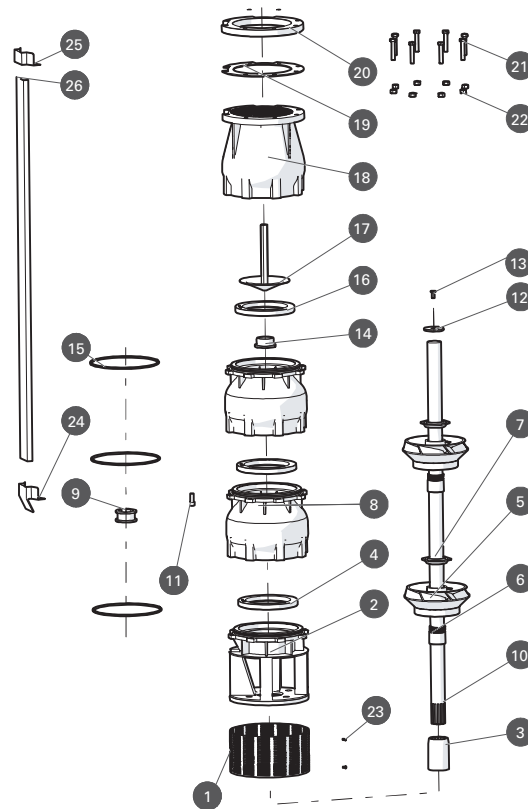

N° Code	Description	LMS Execution	LMX Execution	LMD Execution	(*) Q.ty
1	Suction strainer	AISI 304	AISI 316	Duplex	-
2	Suction cage	AISI 304	AISI 316	Duplex	-
3	Joint	AISI 304	AISI 316	Duplex	1
4	Usury ring	NBR	NBR	NBR	N° of St.
5	Impeller	AISI 304	AISI 316	Duplex	-
6	Cone	AISI 304	AISI 316	Duplex	N° of St.
7	Hexagonal ring	AISI 304	AISI 316	Duplex	N° of St.
8	Diffuseur	AISI 304	AISI 316	Duplex	-
9	Bearing bush	NBR	NBR	NBR	N° of St.
10	Pump shaft	AISI 304	AISI 316	Duplex	1
11	N.8 Screw for diffuseur	AISI 304	AISI 316	Duplex	-
12	Ring	AISI 304	AISI 316	Duplex	1
13	Screw for disk	AISI 304	AISI 316	Duplex	1
14	Counterthrust	PTFE + 25% CARBON	PTFE + 25% CARBON	PTFE + 25% CARBON	1
15	O-Ring	NBR	NBR	NBR	N° of St.
16	Gasket valve	NBR	NBR	NBR	1
17	Cap valve	AISI 304	AISI 316	Duplex	-
18	Body valve	AISI 304	AISI 316	Duplex	-
19	Seal counterflange	NBR	NBR	NBR	1
20	Counterflange	AISI 304	AISI 316	Duplex	-
21	N.8 Screw for counterflange	AISI 304	AISI 316	Duplex	-
22	N.8 Nut for counterflange	AISI 304	AISI 316	Duplex	-
23	N.2 Screw for suction strainer	AISI 304	AISI 316	Duplex	-
24	Lower clamp	AISI 304	AISI 316	Duplex	-
25	Upper clamp	AISI 304	AISI 316	Duplex	-
26	Cover cable	AISI 304	AISI 316	Duplex	-

\* Reccomended spare parts quantity

