

50Hz



GENERAL CATALOGUE

Edition 2022

www.pentax-pumps.it

Where there's water there's Pentax



Viale dell'Industria, 1
37040 Veronella (VR) - Italia
Tel. +39 0442 489500
Fax +39 0442 489510
com@pentax-pumps.it
www.pentax-pumps.it

PENTAX s.p.a.



10-12LM & E14 lines

Deepwell Borehole

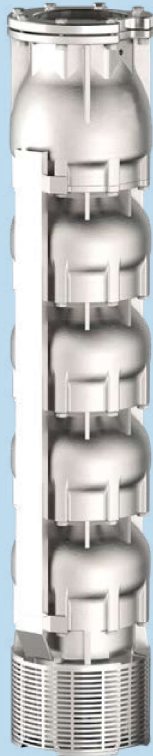

10LM line



12LM line



E14

Submersible multistage centrifugal pumps for 10", 12" and 14" wells. Check valve built into the delivery outlet. Pump flange for coupling with motors are made according to NEMA standards. Most common applications are civil and agricultural. All components are made of stainless steel with lost wax Microfusion technology. The standard material is AISI 304 stainless steel, alternatively the following materials are available on request: AISI 316 Steel, Duplex steel, AISI 904L Steel. Bushing bearings and wear-rings made of sand abrasion-resistant rubber, reverse-Thrust ring in PTFE/Graphite.

General operating data:

- Capacity up to 860 m³/h
- Pressure up to 800 m
- Hydraulic efficiency 10", up to 84,0%
- Hydraulic efficiency 12", up to 82,5%
- Hydraulic efficiency 14", up to 82,3%
- Pressure up to 80 bar
- Powers up to 400 kW
- Rotation speed up to 3600 rpm
- Maximum depth: 350 m
- Maximum quantity of permitted sand: 100 gr/m³
- Drinking water compatibility according to DM174 MEI >= 0,4 (EU directive No.547/2012)
- Performance tolerance: ISO9906-3B.

Construction features

Suction and delivery outlet	AISI 304 (LMS) AISI 316 (LMX - EX) Duplex (LMD - ED) Cast iron (E)
Valve	AISI 304 (LMS) AISI 316 (LMX - EX) Duplex (LMD - ED) Cast iron (E)
Impellers and diffusers	AISI 304 (LMS) AISI 316 (LMX - EX) Duplex (LMD - ED) Cast iron (E)
Upper bushings	NBR rubber
Shaft pump side	AISI 304 (LMS) AISI 316 (LMX) Duplex (LMD) AISI 431 (E - EX - ED)
Quantity of sand in the water	max 100 g/m ³

Motor

Asynchronous 2 pole	rewindable water cooled
Insulation class	Y (max 30 °C) - PPC winding type F (max 50 °C) - PE2+PA or LPE winding type
Protection degree	IP68
Liquid temperature	max 30 °C (max 50 °C on request)
Depth of immersion	max 350 m



Motor 50 Hz - 2900 rpm				Q									
TYPE	Power		400 V	l/min	0	700	1800	2200	2600	3000	3400	3800	4000
	HP	kW			l/sec	0	11,7	30,0	36,7	43,3	50,0	56,7	63,3
	A	m ³ /h	0	42	108	132	156	180	204	228	24		
10LM 190/01 DR20	25	18,5	38,3	H[m]	35	34	32	30	27	24	21	16	14
10LM 190/01	30	22	45,1		42	41	38	36	34	31	28	23	21
10LM 190/02 DR10	50	37	75,8		76	75	70	66	61	55	48	40	35
10LM 190/02	60	45	86,3		83	82	77	73	68	62	55	47	41
10LM 190/03 DR20	75	55	106,2		104	102	95	89	82	73	62	49	42
10LM 190/03	90	66	126,0		125	124	115	109	102	93	83	70	62
10LM 190/04 DR10	100	75	143,2		152	150	140	132	122	110	96	79	70
10LM 190/04	125	92	175,1		166	165	154	146	136	124	110	94	82
10LM 190/05 DR10	150	110	211,0		190	188	175	165	153	138	120	99	87
10LM 190/05 D	150	110	211,0		208	206	192	182	170	155	138	117	103
10LM 190/06 DR10 D	175	130	245,3		228	225	210	198	184	166	144	119	104
10LM 190/06 D	175	130	245,3		250	247	230	218	204	186	166	140	124

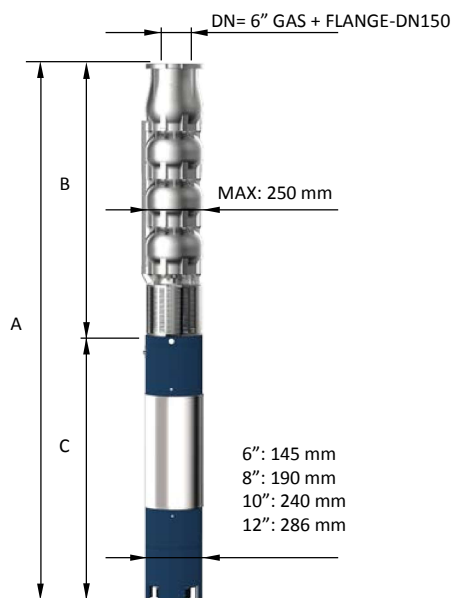

Motor 50 Hz 2900 rpm	DIMENSIONS (mm)			Weight (kg)	
TYPE	A	B	C	M	P
10LM 190/01 DR20	1616	625	991	83	41
10LM 190/01	1696	625	1071	92	41
10LM 190/02 DR10	2146	805	1341	118	56
10LM 190/02	1928	805	1123	178	56
10LM 190/03 DR20	2218	985	1233	200	72
10LM 190/03	2287	985	1302	214	72
10LM 190/04 DR10	2548	1165	1383	230	87
10LM 190/04	2748	1165	1583	270	87
10LM 190/05 DR10	2898	1165	1733	300	87
10LM 190/05 D	2898	1165	1733	300	87
10LM 190/06 DR10 D	2799	1165	1634	385	87
10LM 190/06 D	2799	1165	1634	385	87

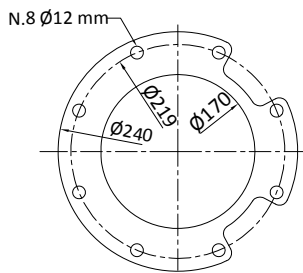

FOR COMMERCIAL TUBE
EXTERNAL DIAMETER: 168,3 mm

Max Eff. % DR20 =	76,5
Max Eff. % DR10 =	77,5
Max Eff. % =	77
Max kW / St. DR20 =	16
Max kW / St. DR10 =	18,5
Max kW / St. =	20,8

Q (flow)	25%	50%	75%	100%
NPSH (m)	3,4	5	7,8	11,8



10LM 190

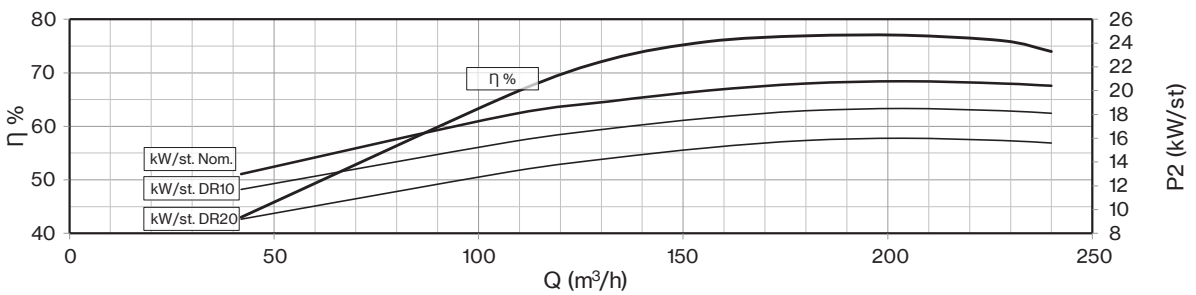
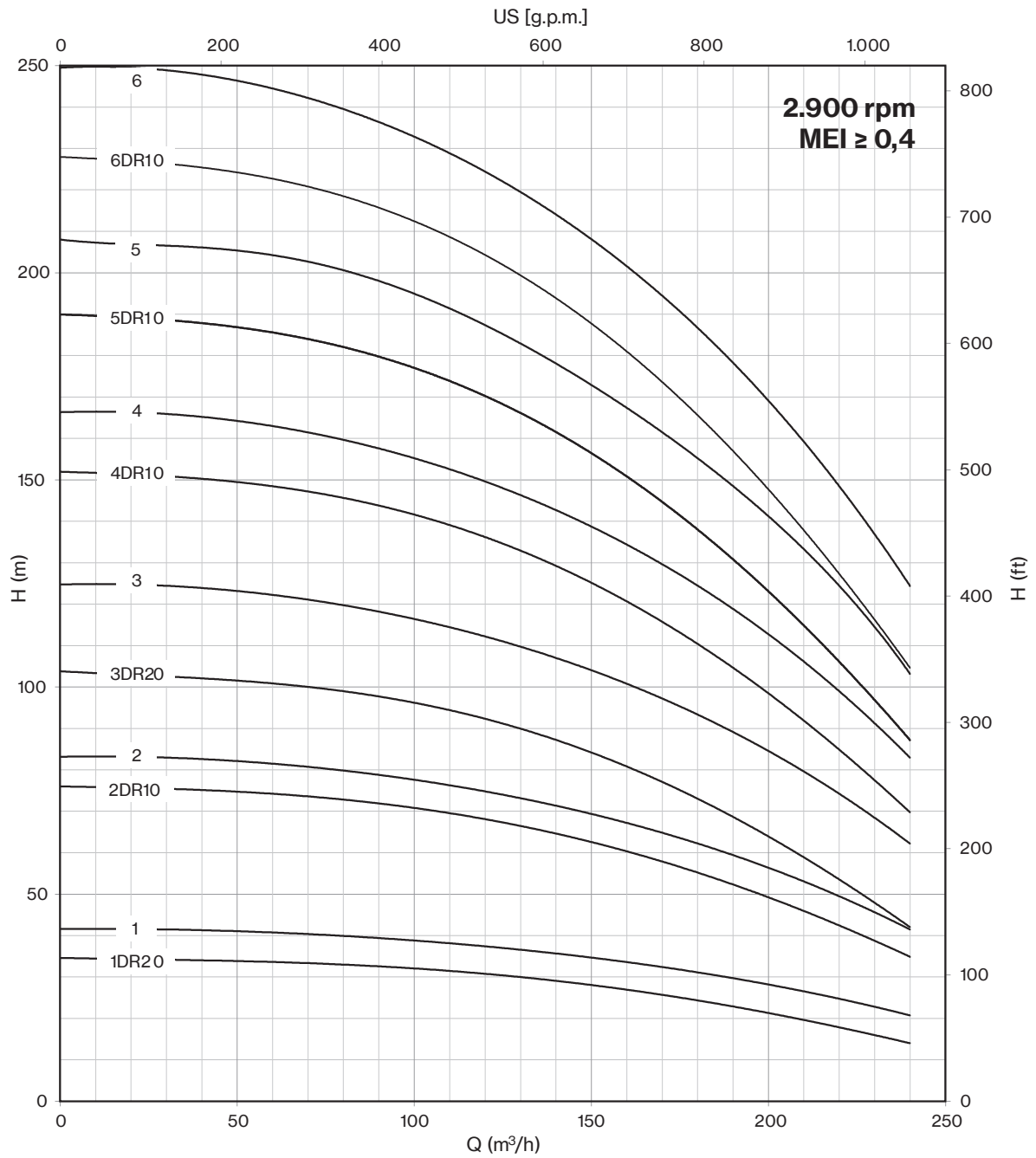

Motor 50 Hz - 2900 rpm				Q									
TYPE	Power		400 V	l/min	0	700	1800	2200	2600	3000	3400	3800	4000
	HP	kW		l/sec	0	11,7	30,0	36,7	43,3	50,0	56,7	63,3	66,7
	A	m ³ /h	0	42	108	132	156	180	204	228	240		
10LM 190/07 DR10 D	175	130	245,3	H[m]	266	263	245	231	214	193	168	139	122
10LM 190/07 D	200	150	277,2		291	288	269	255	238	217	193	164	144
10LM 190/08 DR10 D	200	150	277,2		304	300	280	264	245	221	192	158	139
10LM 190/08 D	250	185	342,2		333	330	307	291	272	248	221	187	165
10LM 190/09 D	300	220	430,0		374	371	346	328	306	279	248	211	185
10LM 190/010 D	300	220	430,0		416	412	384	364	340	310	276	234	206
10LM 190/011 D	340	250	481,0		458	453	422	400	374	341	304	257	227

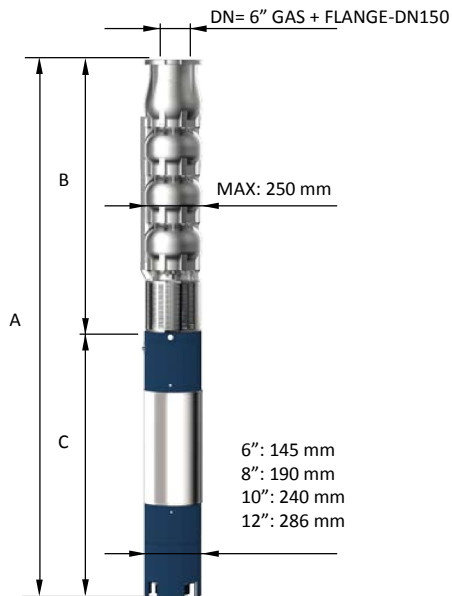

Motor 50 Hz 2900 rpm	DIMENSIONS (mm)			Weight (kg)	
TYPE	A	B	C	M	P
10LM 190/07 DR10 D	3339	1705	1634	385	134
10LM 190/07 D	3439	1705	1734	415	134
10LM 190/08 DR10 D	3619	1885	1734	415	149
10LM 190/08 D	3869	1885	1984	480	149
10LM 190/09 D	4175	2065	2110	700	165
10LM 190/010 D	4355	2245	2110	700	180
10LM 190/011 D	4705	2425	2280	775	196

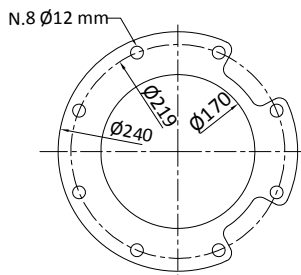

FOR COMMERCIAL TUBE
EXTERNAL DIAMETER: 168,3 mm

Max Eff. % DR20 =	76,5
Max Eff. % DR10 =	77,5
Max Eff. % =	77
Max kW / St. DR20 =	16
Max kW / St. DR10 =	18,5
Max kW / St. =	20,8

Q (flow)	25%	50%	75%	100%
NPSH (m)	3,4	5	7,8	11,



10LM 190

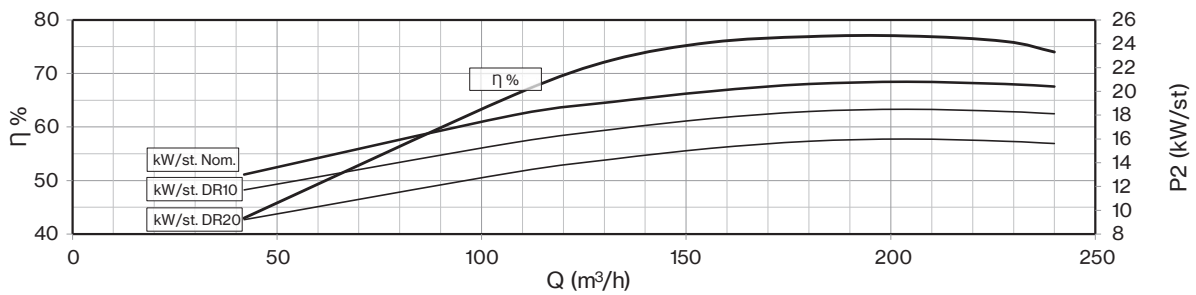
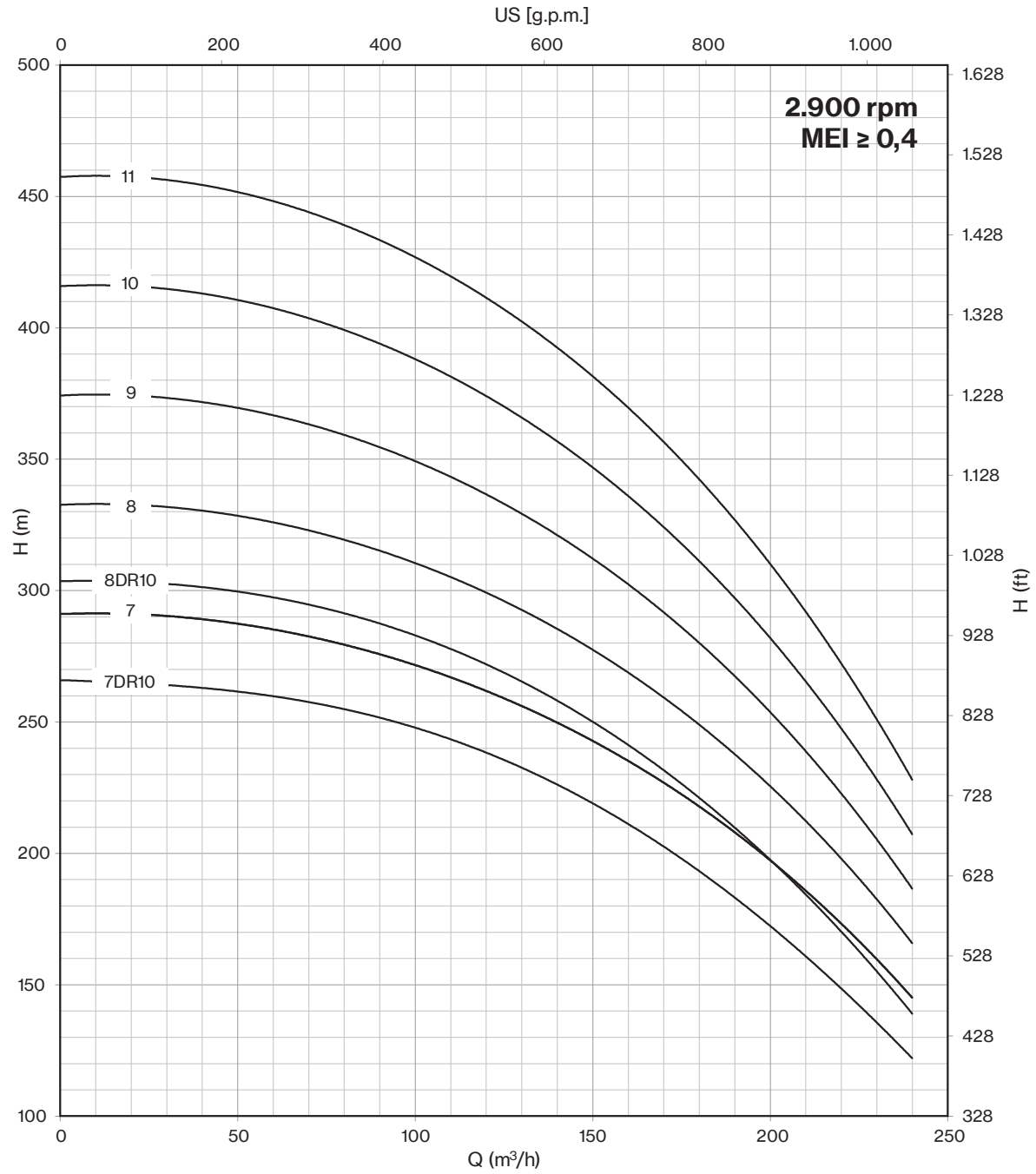

Motor 50 Hz - 2900 rpm				Q									
TYPE	Power		400 V	l/min	0	800	2200	2600	3000	3400	3800	4200	4600
	HP	kW		l/sec	0	13,3	36,7	43,3	50,0	56,7	63,3	70,0	76,7
	A	m3/h	0	48	132	156	180	204	228	252	2		
10LM 230/01 DR20	25	18,5	38,3	H[m]	37	36	31	29	27	25	23	19	16
10LM 230/01	35	26	52,9		44	43	38	36	34	32	30	26	23
10LM 230/02 DR20	50	37	75,8		74	71	62	58	54	50	45	38	32
10LM 230/02	75	55	106,2		88	85	75	72	68	64	59	53	46
10LM 230/03 DR20	75	55	106,2		110	107	93	87	81	75	68	57	48
10LM 230/03 DR10	90	66	126,0		121	116	102	98	92	86	78	68	59
10LM 230/03	100	75	143,2		131	128	113	108	102	96	89	79	69
10LM 230/04 DR10	125	92	175,1		162	154	136	130	122	114	104	91	78
10LM 230/04	125	92	175,1		175	170	150	144	136	128	118	106	92
10LM 230/05 DR10 D	150	110	211,0		202	193	170	163	153	143	130	114	98
10LM 230/05 D	175	130	245,3		219	213	188	180	170	160	148	132	115
10LM 230/06 DR10 D	175	130	245,3		242	231	204	195	183	171	156	137	117
10LM 230/06 D	200	150	277,2		263	255	225	216	204	192	178	159	138

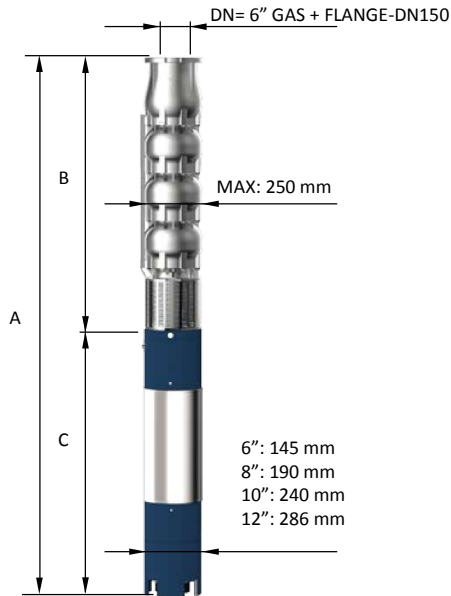

Motor 50 Hz 2900 rpm	DIMENSIONS (mm)			Weight (kg)	
TYPE	A	B	C	M	P
10LM 230/01 DR20	1616	625	991	83	41
10LM 230/01	1806	625	1181	100	41
10LM 230/02 DR20	2146	805	1341	118	56
10LM 230/02	2038	805	1233	200	56
10LM 230/03 DR20	2218	985	1233	200	72
10LM 230/03 DR10	2287	985	1302	214	72
10LM 230/03	2368	985	1383	230	72
10LM 230/04 DR10	2748	1165	1583	270	87
10LM 230/04	2748	1165	1583	270	87
10LM 230/05 DR10 D	3078	1345	1733	300	103
10LM 230/05 D	3078	1345	1733	300	103
10LM 230/06 DR10 D	3159	1525	1634	385	118
10LM 230/06 D	3159	1525	1634	385	118

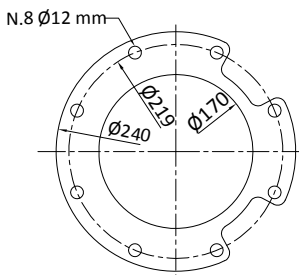

FOR COMMERCIAL TUBE
EXTERNAL DIAMETER: 168,3 mm

Max Eff. % DR20 =	78,4
Max Eff. % DR10 =	79,5
Max Eff. % =	79,2
Max kW / St. DR20 =	17,5
Max kW / St. DR10 =	19,5
Max kW / St. =	22,8

Q (flow)	25%	50%	75%	100%
NPSH (m)	3,4	5	7,8	11,



10LM 230

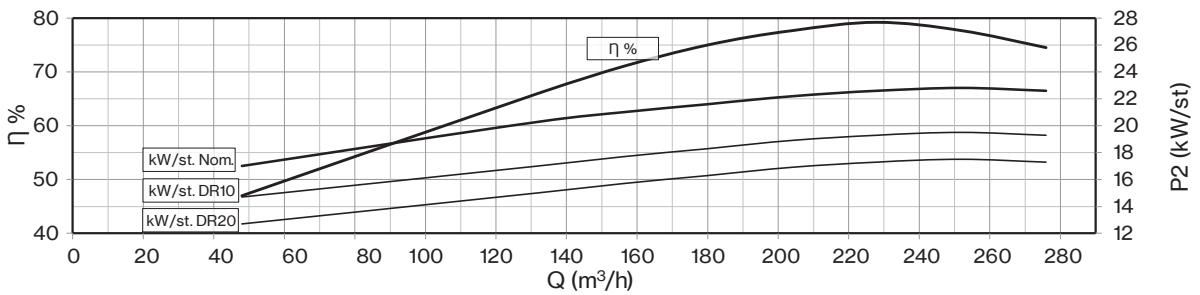
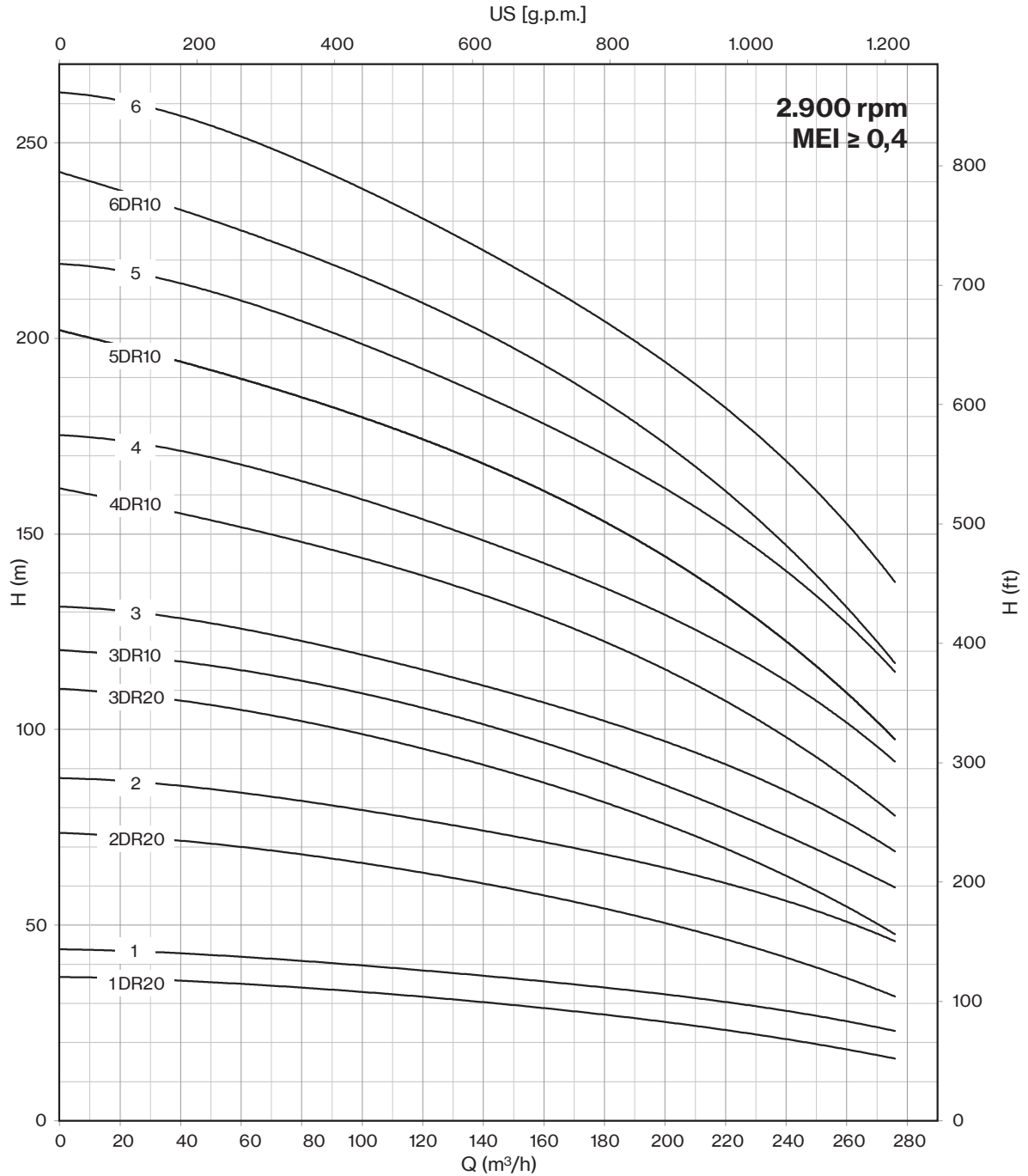

Motor 50 Hz - 2900 rpm				Q									
TYPE	Power		400 V	l/min	0	800	2200	2600	3000	3400	3800	4200	4600
	HP	kW		l/sec	0	13,3	36,7	43,3	50,0	56,7	63,3	70,0	76,7
	A	m ³ /h	0	48	132	156	180	204	228	252	2		
10LM 230/07 DR10 D	200	150	277,2	H[m]	283	270	238	228	214	200	182	160	137
10LM 230/07 D	225	165	313,3		307	298	263	252	238	224	207	185	161
10LM 230/08 DR10 D	225	165	313,3		323	308	272	261	245	229	208	182	157
10LM 230/08 D	250	185	342,2		350	340	301	288	272	256	237	211	184
10LM 230/09 D	300	220	430,0		394	383	338	324	306	288	266	238	207
10LM 230/10 D	340	250	481,0		438	425	376	360	340	320	296	264	230
10LM 230/11 D	340	250	481,0		482	468	413	396	374	352	326	291	253

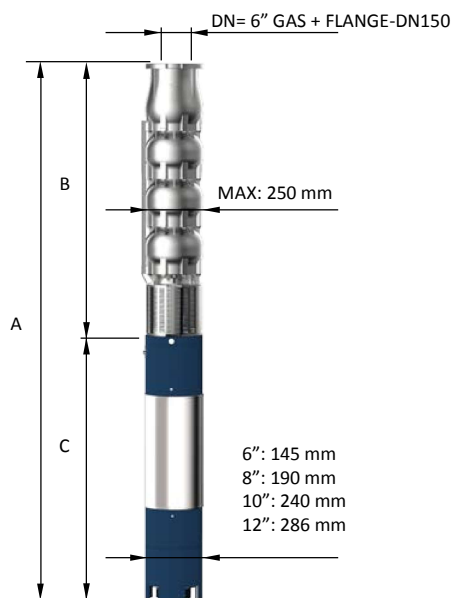

Motor 50 Hz 2900 rpm	DIMENSIONS (mm)			Weight (kg)	
TYPE	A	B	C	M	P
10LM 230/07 DR10 D	3439	1705	1734	415	134
10LM 230/07 D	3559	1705	1854	444	134
10LM 230/08 DR10 D	3739	1885	1854	444	149
10LM 230/08 D	3869	1885	1984	480	149
10LM 230/09 D	4175	2065	2110	700	165
10LM 230/10 D	4355	2245	2110	700	180
10LM 230/11 D	4705	2425	2280	775	196

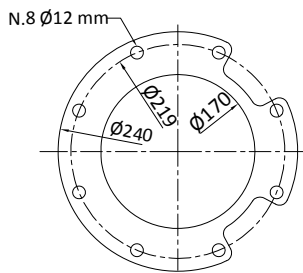

FOR COMMERCIAL TUBE
EXTERNAL DIAMETER: 168,3 mm

Max Eff. % DR20 =	78,4
Max Eff. % DR10 =	79,5
Max Eff. % =	79,2
Max kW / St. DR20 =	17,5
Max kW / St. DR10 =	19,5
Max kW / St. =	22,8

Q (flow)	25%	50%	75%	100%
NPSH (m)	3,4	5	7,8	11,8



10LM 230

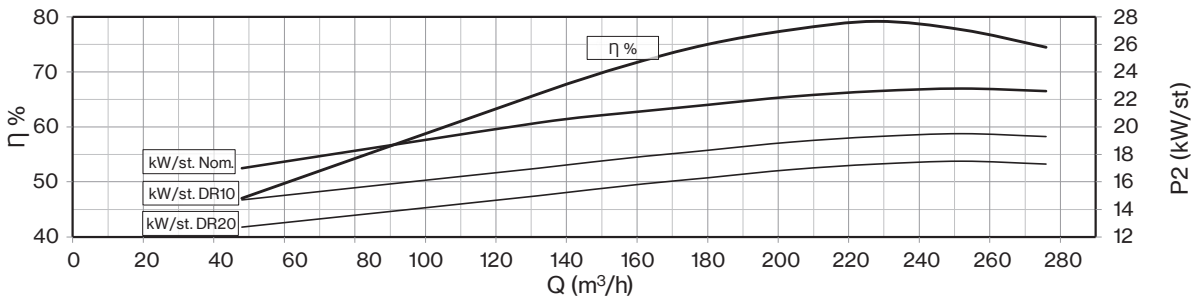
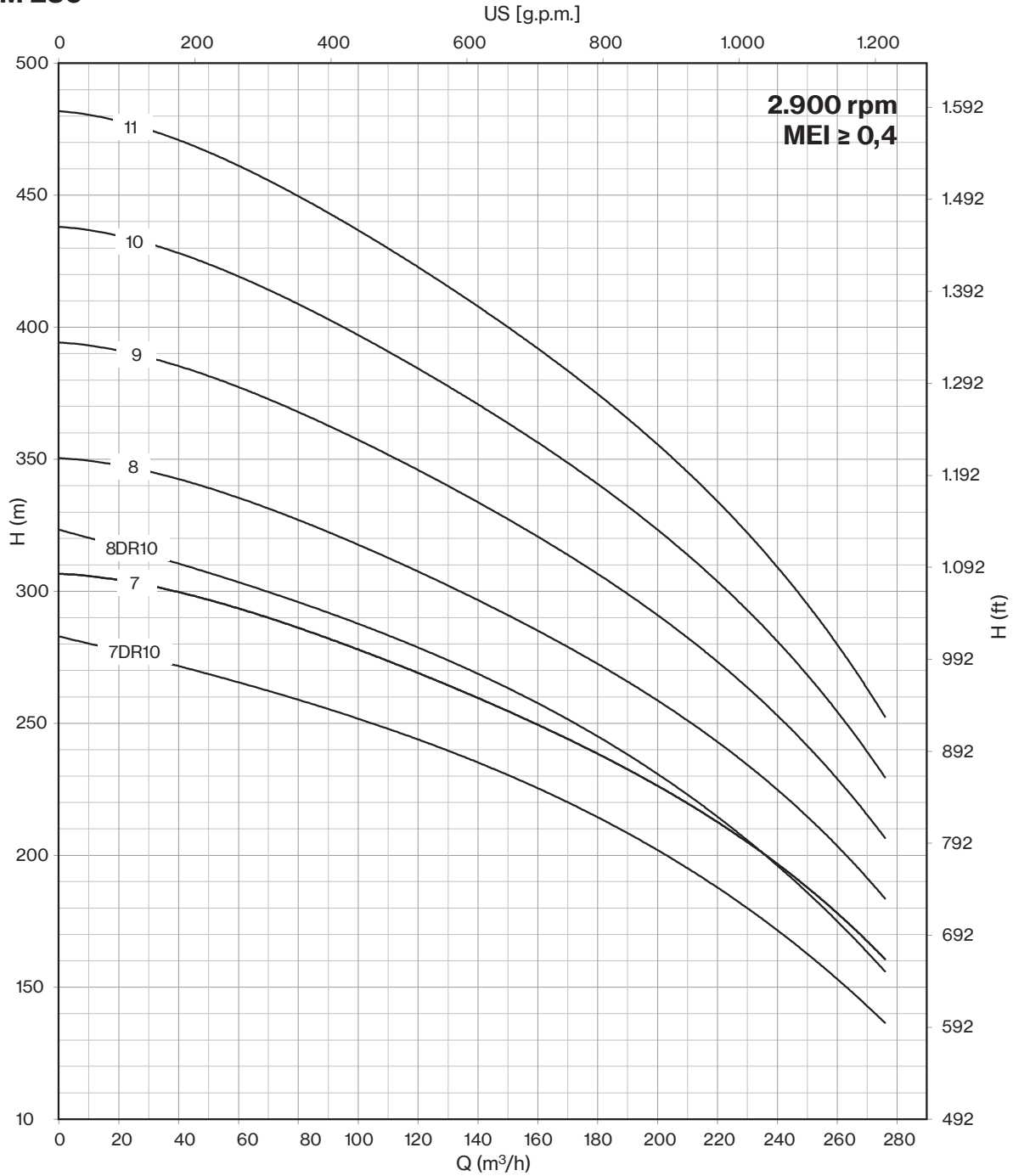

Motor 50 Hz - 2900 rpm				Q									
TYPE	Power		400 V	l/min	0	1000	3200	3600	4000	4400	4800	5000	52
	HP	kW			A	l/sec	16,7	53,3	60,0	66,7	73,3	80,0	83,3
					m ³ /h	0	60	192	216	240	264	288	300
10LM 250/01 DR20	25	18,5	38,3	H[m]	31	31	27	25	23	21	18	17	14
10LM 250/01	40	30	61,1		44	42	34	32	30	28	26	25	24
10LM 250/02 DR20	50	37	75,8		63	62	54	50	46	42	36	33	27
10LM 250/02	75	55	106,2		88	84	67	64	59	56	52	50	48
10LM 250/03 DR10	100	75	143,2		107	107	93	86	80	73	65	59	53
10LM 250/03	125	92	175,1		132	126	101	96	89	83	78	75	72
10LM 250/04 DR10	125	92	175,1		143	142	124	115	107	97	87	79	70
10LM 250/04 D	150	110	211,0		176	168	134	128	118	111	104	100	96
10LM 250/05 DR10 D	175	130	245,3		179	178	155	144	134	121	109	99	88
10LM 250/05 D	200	150	277,2		220	210	168	160	148	139	130	125	120
10LM 250/06 D	225	165	313,3	264	252	202	192	178	167	156	150	144	

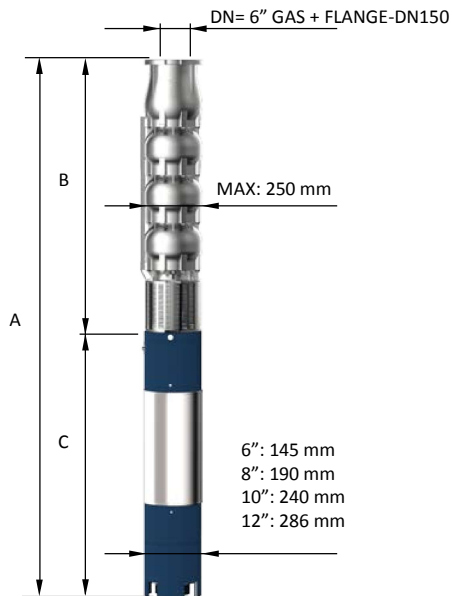

Motor 50 Hz 2900 rpm	DIMENSIONS (mm)			Weight (kg)	
TYPE	A	B	C	M	P
10LM 250/01 DR20	1616	625	991	83	41
10LM 250/01	1876	625	1251	108	41
10LM 250/02 DR20	2146	805	1341	118	57
10LM 250/02	2038	805	1233	200	57
10LM 250/03 DR10	2368	985	1383	230	72
10LM 250/03	2568	985	1583	270	72
10LM 250/04 DR10	2748	1165	1583	270	88
10LM 250/04 D	2898	1165	1733	300	88
10LM 250/05 DR10 D	2979	1345	1634	385	103
10LM 250/05 D	2979	1345	1634	385	103
10LM 250/06 D	3379	1525	1854	444	119

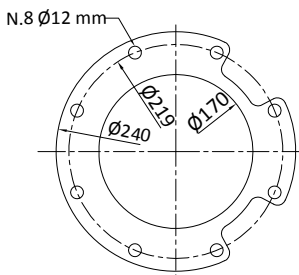

FOR COMMERCIAL TUBE
EXTERNAL DIAMETER: 168,3 mm

Max Eff. % DR20 =	79
Max Eff. % DR10 =	79,5
Max Eff. % =	79,3
Max kW / St. DR20 =	18
Max kW / St. DR10 =	22,5
Max kW / St. =	27,4

Q (flow)	25%	50%	75%	100%
NPSH (m)	3,4	5	7,8	11,



10LM 250

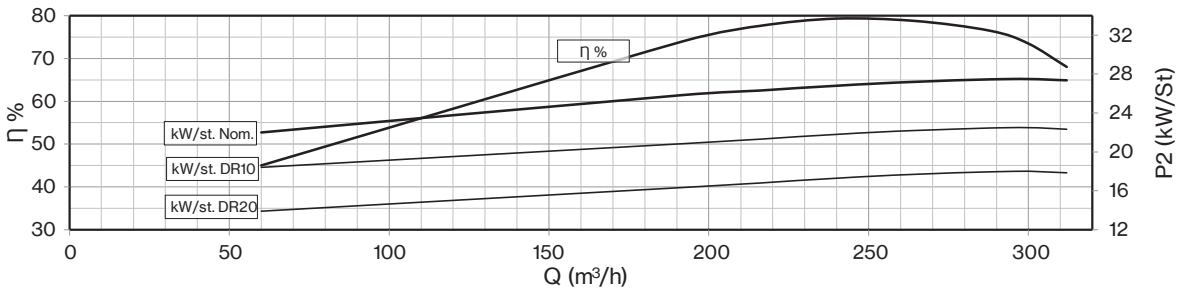
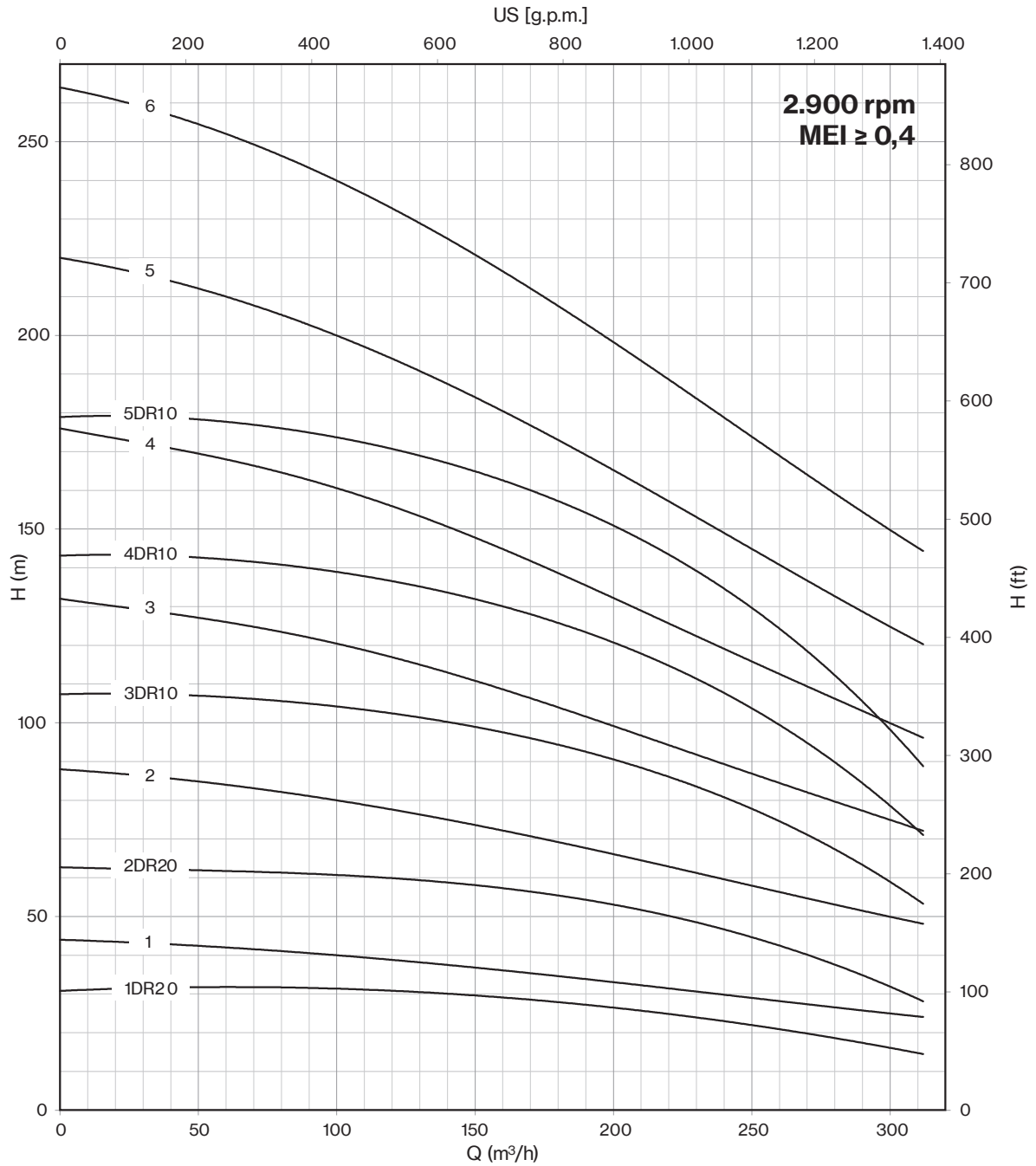

10LM 250

Motor 50 Hz - 2900 rpm				Q									
TYPE	Power		400 V	l/min	0	1000	3200	3600	4000	4400	4800	5000	520
	HP	kW		l/sec	0	16,7	53,3	60,0	66,7	73,3	80,0	83,3	86
	A	m ³ /h	0	60	192	216	240	264	288	300	312		
10LM 250/07 DR10 D	225	165	313,3	H[m]	251	249	217	202	188	169	153	139	123
10LM 250/07 D	300	220	430,0		308	294	235	224	207	195	182	175	168
10LM 250/08 D	300	220	430,0		352	336	269	256	237	222	208	200	192
10LM 250/09 D	340	250	481,0		396	378	302	288	266	250	234	225	216
10LM 250/10 D	400	300	551,0		440	420	336	320	296	278	260	250	240
10LM 250/11 D	450	330	620,0		484	462	370	352	326	306	286	275	264
10LM 250/12 D	450	330	620,0		528	504	403	384	355	334	312	300	288

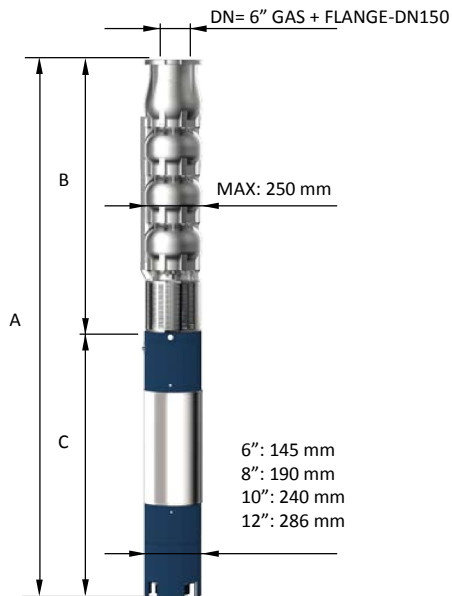

Motor 50 Hz 2900 rpm	Dimensions (mm)			Weight (kg)	
TYPE	A	B	C	M	P
10LM 250/07 DR10 D	3559	1705	1854	444	134
10LM 250/07 D	3815	1705	2110	700	134
10LM 250/08 D	3995	1885	2110	700	150
10LM 250/09 D	4345	2065	2280	775	165
10LM 250/10 D	4525	2245	2280	775	181
10LM 250/11 D	4705	2425	2280	775	196
10LM 250/12 D	4765	2605	2160	906	212

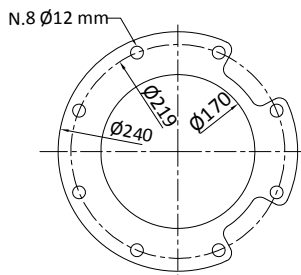

FOR COMMERCIAL TUBE
EXTERNAL DIAMETER: 168,3 mm

Max Eff. % DR20 =	79
Max Eff. % DR10 =	79,5
Max Eff. % =	79,3
Max kW / St. DR20 =	18
Max kW / St. DR10 =	22,5
Max kW / St. =	27,4

Q (flow)	25%	50%	75%	100%
NPSH (m)	3,4	5	7,8	11,



10LM 250

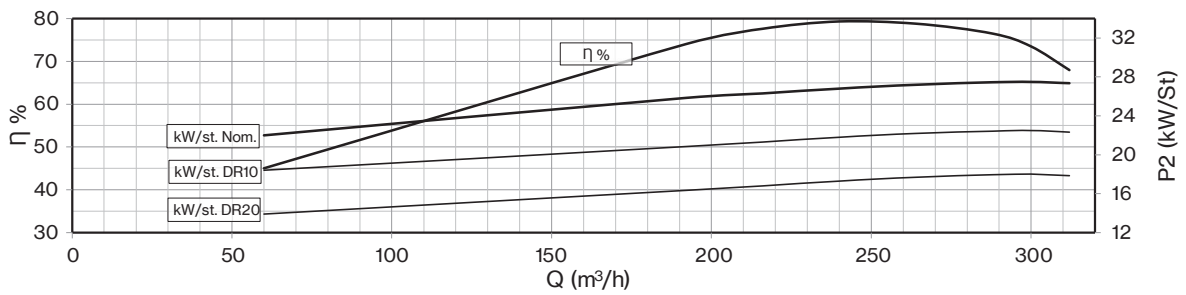
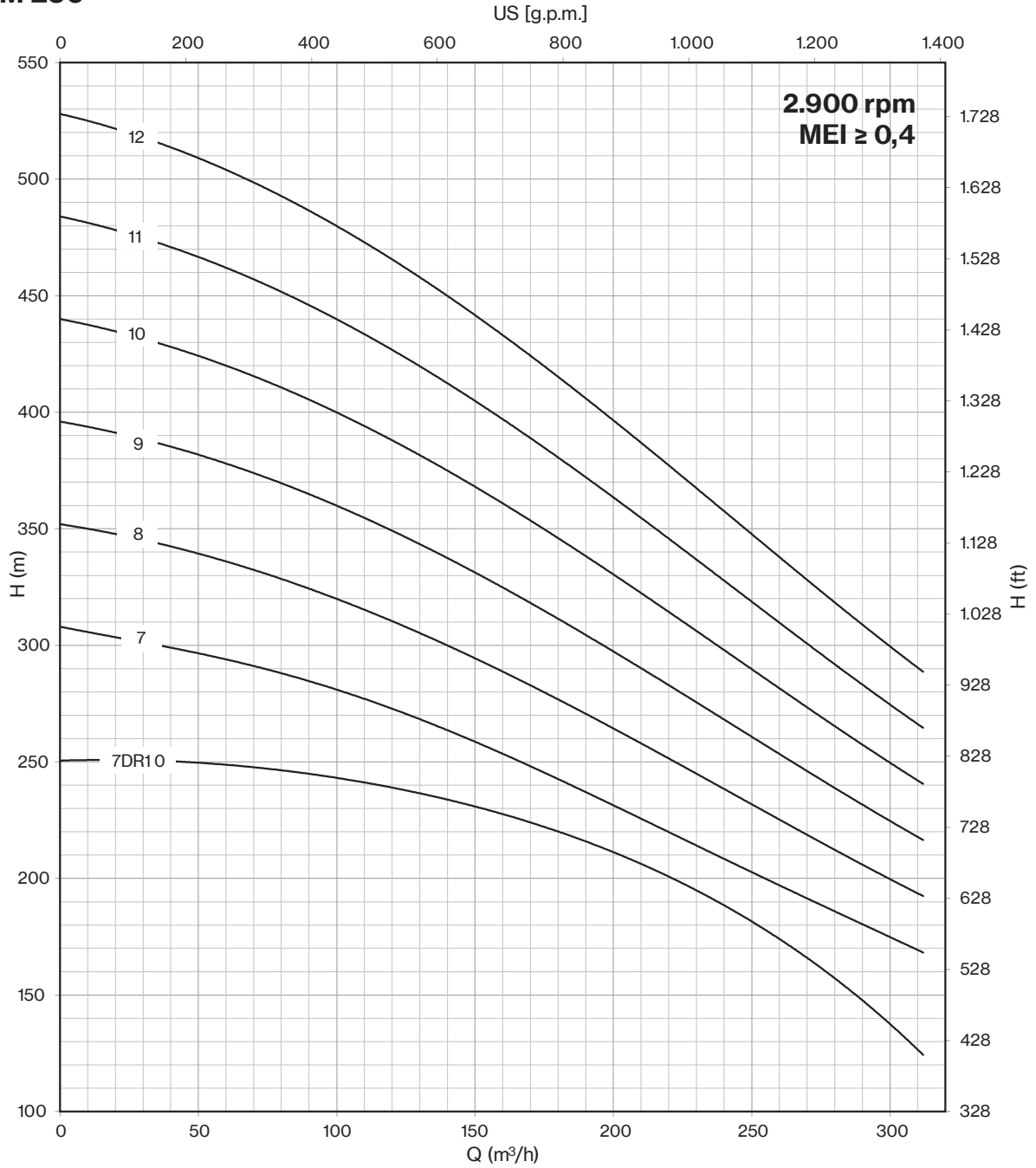

Motor 50 Hz - 2900 rpm				Q												
TYPE	Power		400 V	H[m]	0	1000	3400	3800	4200	4600	5000	5400	580			
	HP	kW			A	l/min	l/sec	m ³ /h	0	16,7	56,7	63,3	70,0	76,7	83,3	90,0
10LM 275/01 DR20	35	26	52,9	H[m]	36	36	28	26	25	23	21	19	16			
10LM 275/01	50	37	75,8		45	44	37	35	34	32	30	28	25			
10LM 275/02 DR20	75	55	106,2		72	71	56	52	50	46	42	39	32			
10LM 275/02	90	66	126,0		90	87	73	70	67	63	60	56	50			
10LM 275/03 DR10	125	92	175,1		122	121	97	92	88	82	77	72	62			
10LM 275/03 D	150	110	211,0		135	131	110	105	101	95	90	85	75			
10LM 275/04 DR10 D	175	130	245,3		163	161	130	123	118	110	103	96	83			
10LM 275/04 D	200	150	277,2		180	175	146	140	134	126	120	113	100			
10LM 275/05 DR10 D	200	150	277,2		204	202	162	154	147	137	129	120	104			
10LM 275/05 D	225	165	313,3		225	219	183	175	168	158	150	141	125			
10LM 275/06 DR10 D	250	185	342,2		245	242	194	185	176	164	155	144	125			
10LM 275/06 D	300	220	430,0		270	262	220	210	202	190	180	169	150			

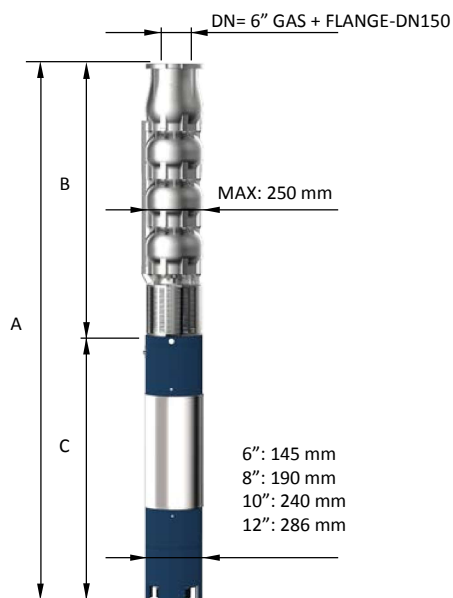

Motor 50 Hz 2900 rpm	DIMENSIONS (mm)			Weight (kg)	
TYPE	A	B	C	M	P
10LM 275/01 DR20	1806	625	1181	100	41
10LM 275/01	1966	625	1341	118	41
10LM 275/02 DR20	2038	805	1233	200	56
10LM 275/02	2107	805	1302	214	56
10LM 275/03 DR10	2568	985	1583	270	72
10LM 275/03 D	2718	985	1733	300	72
10LM 275/04 DR10 D	2799	1165	1634	385	87
10LM 275/04 D	2899	1165	1734	415	87
10LM 275/05 DR10 D	3079	1345	1734	415	103
10LM 275/05 D	3199	1345	1854	444	103
10LM 275/06 DR10 D	3509	1525	1984	480	118
10LM 275/06 D	3635	1525	2110	700	118

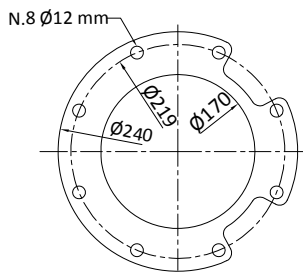

FOR COMMERCIAL TUBE
EXTERNAL DIAMETER: 168,3 mm

Max Eff. % DR20 =	76,1
Max Eff. % DR10 =	77,2
Max Eff. % =	76,5
Max kW / St. DR20 =	25
Max kW / St. DR10 =	29
Max kW / St. =	33

Q (flow)	25%	50%	75%	100%
NPSH (m)	3,4	5	7,8	11,8



10LM 275

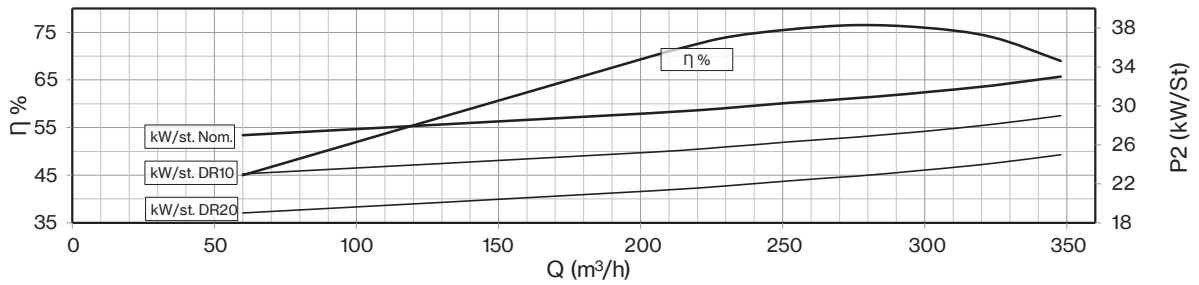
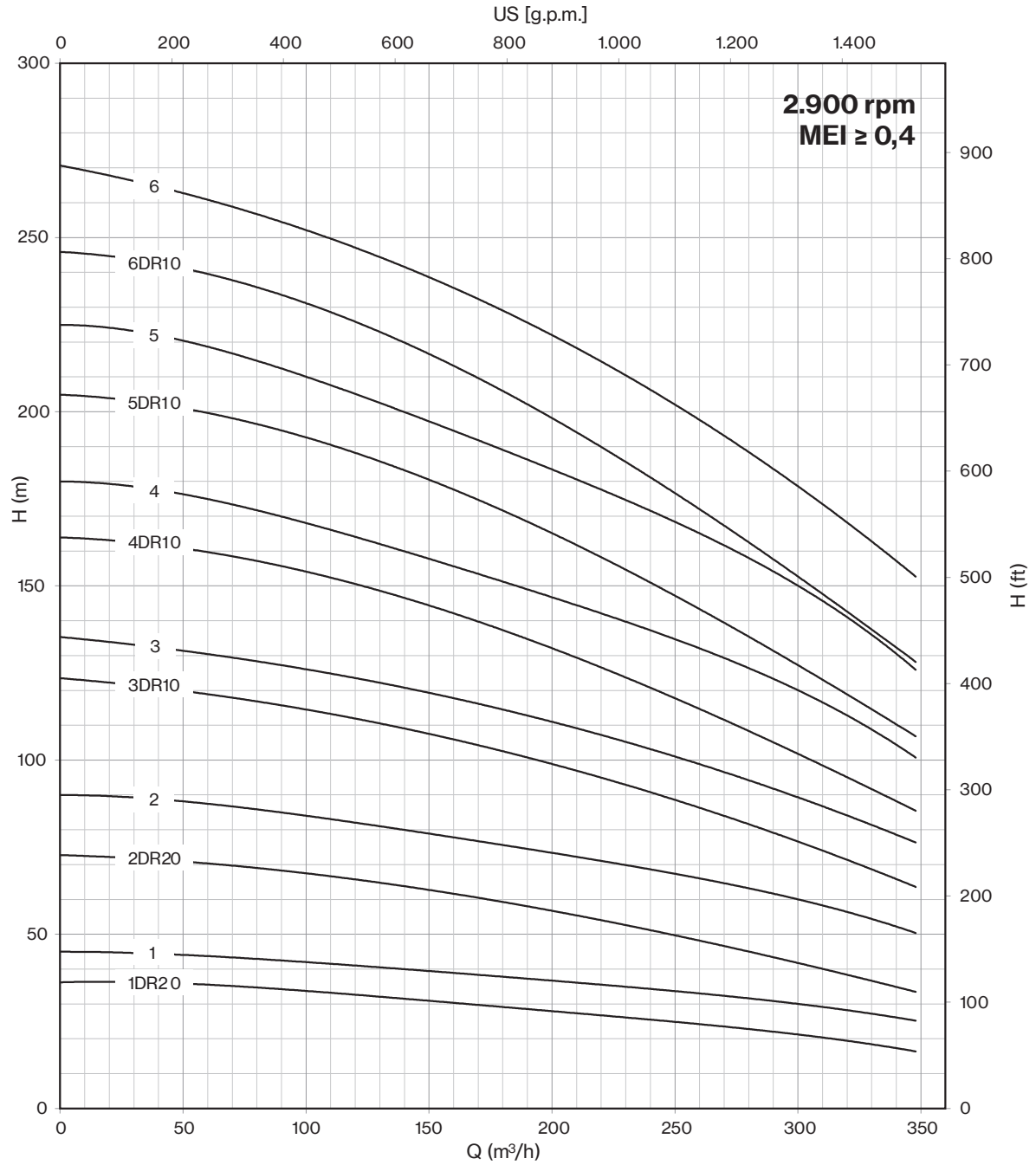

Motor 50 Hz - 2900 rpm				Q									
TYPE	Power		400 V	l/min	0	1000	3400	3800	4200	4600	5000	5400	5800
	HP	kW		l/sec	0	16,7	56,7	63,3	70,0	76,7	83,3	90,0	96,7
	A	m ³ /h	0	60	204	228	252	276	300	324	348		
10LM 275/07 DR10 D	300	220	430,0	H[m]	286	282	227	216	206	192	181	168	146
10LM 275/07 D	340	250	481,0		315	306	256	245	235	221	210	197	175
10LM 275/08 D	400	300	551,0		360	350	293	280	269	253	240	226	200
10LM 275/09 D	400	300	551,0		405	393	329	315	302	284	270	254	225
10LM 275/10 D	450	330	620,0		450	437	366	350	336	316	300	282	250
10LM 275/11 D	500	370	693,0		495	481	403	385	370	348	330	310	275
10LM 275/12 D	550	400	798,0		540	524	439	420	403	379	360	338	300

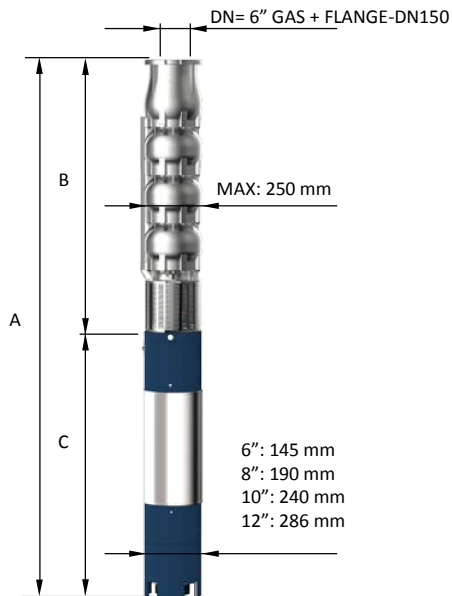

Motor 50 Hz 2900 rpm	DIMENSIONS (mm)			Weight (kg)	
TYPE	A	B	C	M	P
10LM 275/07 DR10 D	3815	1705	2110	700	134
10LM 275/07 D	3985	1705	2280	775	134
10LM 275/08 D	4165	1885	2280	775	149
10LM 275/09 D	4345	2065	2280	775	165
10LM 275/10 D	4405	2245	2160	906	180
10LM 275/11 D	4585	2425	2160	906	196
10LM 275/12 D	4925	2605	2320	1010	211

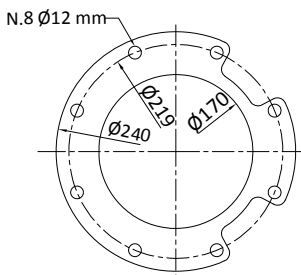

FOR COMMERCIAL TUBE
EXTERNAL DIAMETER: 168,3 mm

Max Eff. % DR20 =	76,1
Max Eff. % DR10 =	77,2
Max Eff. % =	76,5
Max kW / St. DR20 =	25
Max kW / St. DR10 =	29
Max kW / St. =	33

Q (flow)	25%	50%	75%	100%
NPSH (m)	3,4	5	7,8	11,8



10LM 275

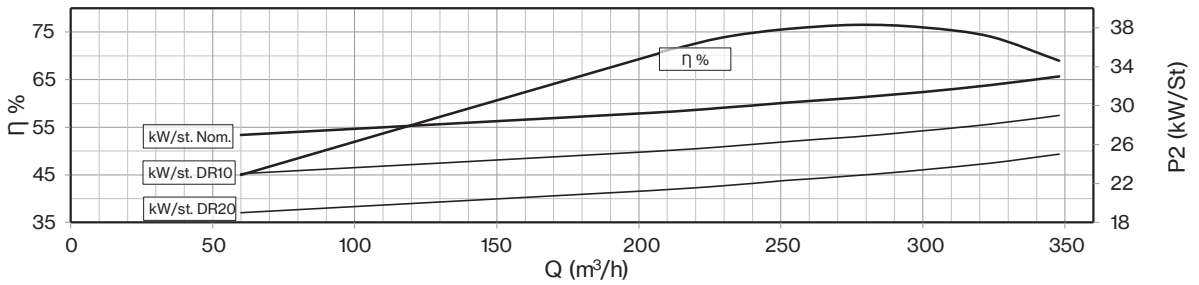
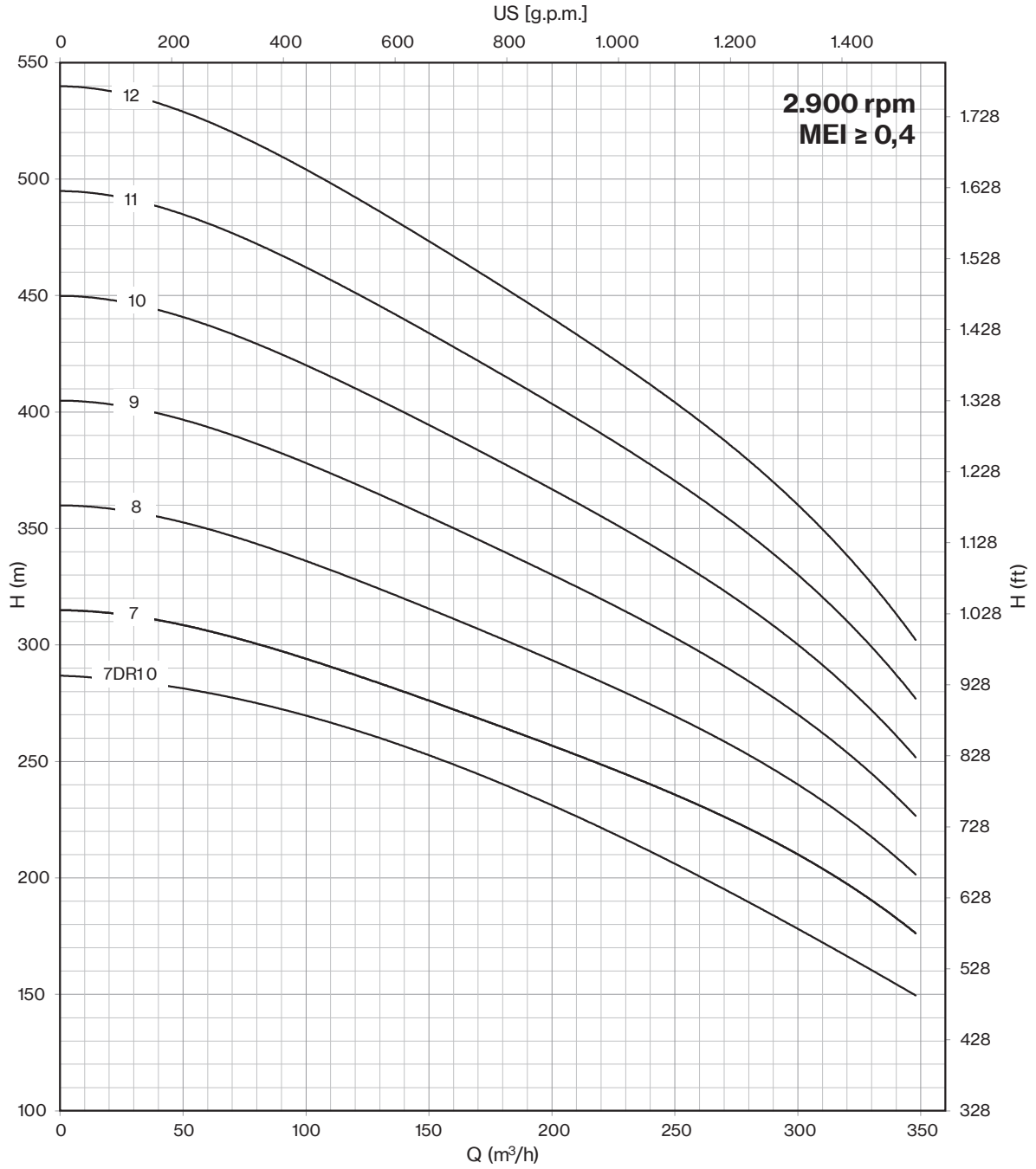

6LM - 8LM - 10LM - 12LM

6LM - 8LM - 10LM - 12LM lines

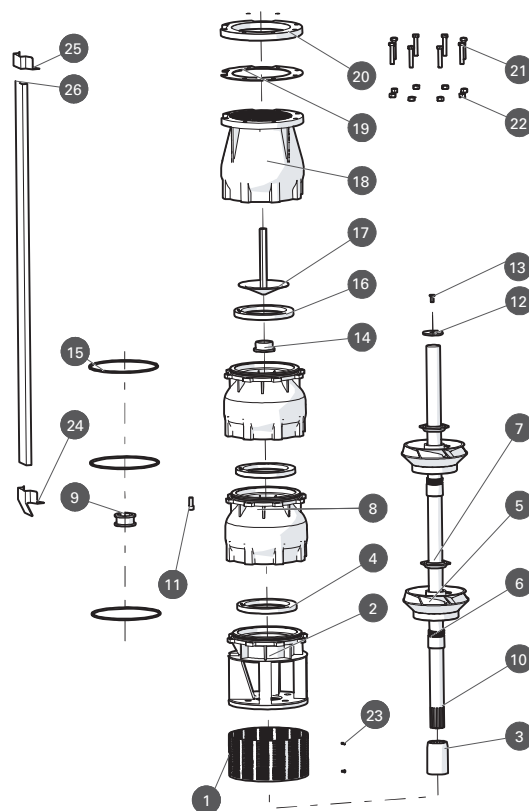

N° Code	Description	LMS Execution	LMX Execution	LMD Execution	(*) Q.ty
1	Suction strainer	AISI 304	AISI 316	Duplex	-
2	Suction cage	AISI 304	AISI 316	Duplex	-
3	Joint	AISI 304	AISI 316	Duplex	1
4	Usury ring	NBR	NBR	NBR	N° of St.
5	Impeller	AISI 304	AISI 316	Duplex	-
6	Cone	AISI 304	AISI 316	Duplex	N° of St.
7	Hexagonal ring	AISI 304	AISI 316	Duplex	N° of St.
8	Diffuseur	AISI 304	AISI 316	Duplex	-
9	Bearing bush	NBR	NBR	NBR	N° of St.
10	Pump shaft	AISI 304	AISI 316	Duplex	1
11	N.8 Screw for diffuseur	AISI 304	AISI 316	Duplex	-
12	Ring	AISI 304	AISI 316	Duplex	1
13	Screw for disk	AISI 304	AISI 316	Duplex	1
14	Counterthrust	PTFE + 25% CARBON	PTFE + 25% CARBON	PTFE + 25% CARBON	1
15	O-Ring	NBR	NBR	NBR	N° of St.
16	Gasket valve	NBR	NBR	NBR	1
17	Cap valve	AISI 304	AISI 316	Duplex	-
18	Body valve	AISI 304	AISI 316	Duplex	-
19	Seal counterflange	NBR	NBR	NBR	1
20	Counterflange	AISI 304	AISI 316	Duplex	-
21	N.8 Screw for counterflange	AISI 304	AISI 316	Duplex	-
22	N.8 Nut for counterflange	AISI 304	AISI 316	Duplex	-
23	N.2 Screw for suction strainer	AISI 304	AISI 316	Duplex	-
24	Lower clamp	AISI 304	AISI 316	Duplex	-
25	Upper clamp	AISI 304	AISI 316	Duplex	-
26	Cover cable	AISI 304	AISI 316	Duplex	-

* Reccomended spare parts quantity

